

SPECTRORADIOMETRY METHODS: A GUIDE TO PHOTOMETRY AND VISIBLE SPECTRORADIOMETRY

Written By
William E. Schneider, Richard Young, Ph.D

1. SPECTRORADIOMETRY METHODS

1.1. Spectroradiometrics vs Photometric Quantities (Definitions and Units)

1.1.1. Radiometric Quantities.

1.1.2. Photometric Quantities.

1.1.3. Spectroradiometric Quantities.

1.1.4. Transmittance.

1.1.5. Reflectance.

1.1.6. Spectral Responsivity

1.2. SPECTRORADIOMETRIC STANDARDS.

1.2.1. Blackbody Standards.

1.2.2. Basic Spectroradiometric Standards.

1.2.3. Special Purpose Spectroradiometric Standards.

1.3. SPECTRORADIOMETRIC INSTRUMENTATION - GENERAL

1.3.1. The Wavelength Dispersing Element

1.3.2. Collimating and Focusing Optics

1.3.3. The Wavelength Drive Mechanism

1.3.4. Stray Light

1.3.5. Blocking Filters

1.3.6. Grating Optimization

1.3.7. Detectors

1.3.8. Signal Detection Systems

1.3.9. Monochromator Throughput and Calibration Factors

1.3.10. Slits and Aperture Selection

1.3.11. Throughput vs Bandpass

1.4. PERFORMANCE SPECIFICATIONS

1.4.1. f-number

1.4.2. Wavelength Accuracy / Resolution / Repeatability

1.4.3. Bandpass

1.4.4. Sensitivity and Dynamic Range

1.4.5. Stray Light

1.4.6. Scanning Speeds

1.4.7. Stability

1.4.8. Software and Automation

1.5. SPECTRORADIOMETRIC MEASUREMENT SYSTEMS.

1.5.1. Source Measurements / Input Optics / System Calibration

1.5.2. Spectral Transmittance

1.5.3. Spectral Reflectance

1.5.4. Spectral Responsivity.

1.6. CALCULATING PHOTOMETRIC AND COLORMETRIC PARAMETERS

1.6.1. Tristimulus Values

1.6.2. Photometric Output Calculations

1.6.3. CIE 1931 Chromaticity Calculations

1.6.4. UCS 1976 u , v , u' , and v' Coordinates Calculations

1.6.5. Correlated Color Temperature Calculations

1.6.6. CIE LAB/LUV Color Space Calculations

1.6.7. Color Difference and Color Rendering Calculations

1.6.8. Detector Photometric Parameters

1.6.9. Limits in Using Photometric and Colormetric Calculations

1.7. ACCURACY AND ERRORS

1.7.1. Random, Systematic and Periodic Errors

1.7.2. Error Sources Photometry and Spectroradiometry

1. SPECTRORADIOMETRY METHODS

1.1. Spectroradiometrics vs Photometric Quantities (Definitions and Units)

Radiometry is the science and technology of the measurement of electromagnetic radiant energy. It is more commonly referred to simply as “the measurement of optical radiation.” Whereas radiometry involves the measurement the total radiant energy emitted by the radiating source over the entire optical spectrum (1 nm to 1000 μm) and spectroradiometry is concerned with the spectral content of the radiating source, photometry is only concerned with that portion of the optical spectrum to which the human eye is sensitive (380 nm to 780 nm). More specifically, photometry relates to the measurement of radiant energy in the “visible” spectrum as perceived by the standard photometric observer. Loosely, the standard photometric observer can be thought of as the “average” human.

A number of radiometric, spectroradiometric, and photometric quantities are used to describe a radiating source. Although there has been some disagreement in the past with respect to these definitions, those described herein are those most commonly used at the present time.

1.1.1. Radiometric Quantities

The radiometric quantities listed below are those most frequently used in the measurement of optical radiation (1,2).

Radiant Energy is the total energy emitted from a radiating source (J).

Radiant Energy Density is the radiant energy per unit volume (J m⁻³).

Radiant Power or Flux is the radiant energy per unit time (J s⁻¹ or Watts).

Radiant Exitance is the total radiant flux emitted by a source divided by the surface area of the source (W m⁻²).

Irradiance is the total radiant flux incident on an element of surface divided by the surface area of that element (W m⁻²).

Radiant Intensity is the total radiant flux emitted by a source per unit solid angle in a given direction (W sr⁻¹).

QUANTITY	SYMBOL	DEFINING EQUATION	UNITS
Radiant Energy	Q, Q _e		J (Joule)
Radiant Energy Density	w, w _e	= dQ / dV	J m ⁻³
Radiant Power or Flux	Φ, Φ _e	= dQ / dt	J s ⁻¹ or W (Watt)
Radiant Exitance	M, M _e	= dΦ / dA _{source}	W m ⁻²
Irradiance	E, E _e	= dΦ / dA _{surface}	W m ⁻²
Radiant Intensity	I, I _e	= dΦ / dΩ	W sr ⁻¹
Radiance	L, L _e	= d ² Φ / dΩ(dAcosθ) = dI / dAcosθ	W m ⁻² sr ⁻¹
Emissivity	ε	= M / M _{blackbody}	

Table 1.1 Fundamental Radiometric Quantities

Radiance is the radiant intensity of a source divided by the area of the source (W sr⁻¹ m⁻²). **Figure 1.1** shows the geometry for defining radiance. Note, a steradian is defined as the solid angle that, having its vertex in the center of a sphere, cuts off an area of the surface of the sphere equal to that of a square with sides of length equal to the radius of the sphere.

Emissivity is the ratio of the radiant flux density of a source to that of a blackbody radiator at the same temperature.

Pure physical quantities for which radiant energy is evaluated in energy units are defined in **Table 1.1**.

1.1.2. Photometric Quantities

When the radiometric quantities listed in **Table 1.1** are evaluated by means of a standard photometric observer, they correspond to an analogous photometric quantity (see **Table 1.2**). Each pair of quantities, radiometric and photometric, are represented by the same principal symbol (save “emissivity” and “luminous efficacy”) and are distinguished only by the subscript. The subscript “e” (or no subscript) is used in the case of physical (radiometric) quantities and the subscript “v” is used for photometric quantities.

Although there are many common terms used to define photometric light output, the basic unit of measurement of light is the lumen (3). All other photometric quantities involve the lumen. The eight fundamental photometric quantities concerned with the measurement of light are defined below.

Luminous Energy is the total energy as perceived by a standard 2° observer (lm s).

Luminous Energy Density is the luminous energy per unit volume (lm s m⁻³).

Luminous Flux is the luminous energy per unit time (lm).

Luminous Exitance is the ratio of the luminous flux emitted to the surface area of the source (lm m⁻²).

Illuminance is the luminous flux per unit area incident on a surface. It is the luminous flux divided by the area of the surface when the surface is uniformly irradiated (lm m⁻²).

Luminous Intensity is the luminous flux per unit solid angle in the direction in question (lm sr⁻¹ or candela).

Luminance is the ratio of the luminous intensity to the area of the source (cd m⁻²).

Luminous Efficacy is the ratio of the total luminous flux to the total radiant flux (lm W⁻¹).

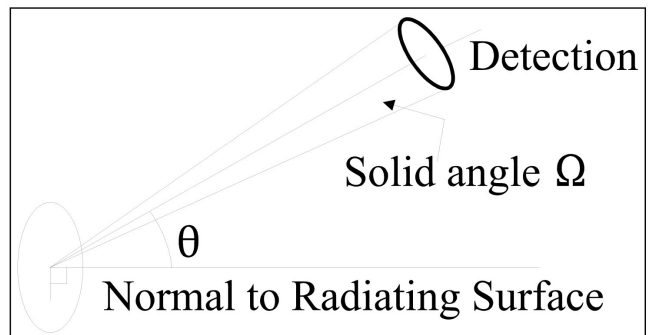

Figure 1.1 Geometry for defining radiance

OPTRONIC™
LABORATORIES

Application Note: A14 Jan 2019

As part of our policy of continuous product improvement, we reserve the right to change specifications at any time.

QUANTITY	SYMBOL	DEFINING EQUATION	UNITS
Luminous Energy	Q_v	$= K_m \int V(\lambda) \cdot Q(\lambda) \cdot d\lambda \cdot 0.25$	lm s
Luminous Energy Density	w_v	$= dQ_v / dV$	lm s m ⁻³
Luminous Flux	Φ_v	$= dQ_v / dt$	lm (lumen)
Luminous Exitance	M_v	$= d\Phi_v / dA_{\text{source}}$	lm m ⁻²
Illuminance	E_v	$= d\Phi_v / dA_{\text{surface}}$	lm m ⁻²
Luminous Intensity	I_v	$= d\Phi_v / d\Omega$	lm sr ⁻¹ or cd (candela)
Luminance	L_v	$= d^2\Phi_v / d\Omega(dA\cos\theta)$ $= dI_v / dA\cos\theta$	m ⁻²
Luminous Efficacy	K	$= \Phi_v / \Phi$	lm W ⁻¹

Table 1.2 Fundamental Photometric Quantities

1.1.3. Spectroradiometric Quantities

When radiant energy, or any related quantity, is measured in terms of its monochromatic components it becomes a function of wavelength. Therefore, the designations for these quantities must be preceded by the adjective "spectral," as in "spectral irradiance." The symbol itself, for each quantity, is followed by the symbol for wavelength (λ). For example, spectral irradiance has the symbol $E(\lambda)$ or $E_e(\lambda)$.

If the spectral distribution of the source is known, the following relationship between the lumen and the Watt can be used to convert from one to the other:

$$\Phi_v = 683 \int \Phi(\lambda) \cdot V(\lambda) \cdot d\lambda \quad [\text{lm}]$$

where $\Phi(\lambda)$ is the spectroradiometric power distribution of the light source (expressed in "Watts per unit wavelength interval"), $V(\lambda)$ is the relative photopic luminous efficacy function (normalized at 555 nm), and λ is the wavelength (usually expressed in nanometers). The value of 683 [lm W⁻¹] is the absolute luminous efficacy at 555 nm.

When a photometric or radiometric measurement of a light source is made, it is not possible to convert from photometric to radiometric units or vice versa unless the spectral distribution of the source is precisely known. In the special case of a monochromatic light source, such as a laser, the equation simplifies as shown below. For example, in the case of a 1mW HeNe laser whose output is at 633 nm, the luminous flux is:

$$\Phi_v = 683 \cdot \Phi(633) \cdot V(633) = 683 \times 10^{-3} \times 0.2353344 = 0.1607 \text{ lumens}$$

In general, a measurement of the spectrometric output of a light source will provide the most accurate photometric data.

1.1.3. Transmittance

Transmittance is the ratio of the transmitted radiant or luminous flux to the incident radiant or luminous flux (4),

$$\text{Luminous Transmittance: } \tau_v = \frac{\Phi_v^t}{\Phi_v^i}$$

$$\text{Spectral Transmittance: } \tau(\lambda) = \frac{\Phi^t(\lambda)}{\Phi^i(\lambda)}$$

where superscript "t" refers to transmitted flux and superscript "i" to incident flux.

The total transmittance (ϑ) of a medium (or object) consists of two parts: regular transmittance (ϑ_r) and diffuse transmittance (ϑ_d) where,

$$\vartheta = \vartheta_r + \vartheta_d$$

If radiant or luminous flux travels through a sample such that the exit angle may be predicted from the entry angle according to Snell's refraction law (5), the transmittance is referred to as regular. When the flux is scattered as it travels through the sample, or on a macroscopic scale Snell's law no longer applies because of the roughness of the surface, the transmittance is referred to as diffuse.

The luminous (or photometric) transmittance of the medium is dependent on the spectral composition of the radiating source. Accordingly, the nature of the radiating source must be specified when determining the photometric transmittance of a medium. For example, the photometric transmittance of a blue filter will be considerably higher when the radiating source is a xenon arc lamp than when the radiating source is a tungsten lamp operating at a color temperature of 2856K.

The photometric transmittance of a medium for a specified radiating source can be determined photometrically or spectroradiometrically. However, the specified radiating source (or a source with the same spectral distribution as the specified source) must be used when employing the photometric technique. Users commonly fail to account for source distributions when performing spectroradiometric calculations. While this is still valid - the photometric transmittance of a medium is equivalent to specifying "an equal energy source," i.e. a source having equal energy at all wavelengths over the visible spectrum - it should be borne in mind that this is not a practical source for comparative photometric measurements.

Photometric transmittance (τ_v) be computed from a knowledge of the spectral transmittance ($\tau(\lambda)$) and the relative spectral distribution of the specified source ($\Phi(\lambda)$) as follows:

$$\tau_v = \int_{\lambda} \tau(\lambda) \cdot \Phi(\lambda) \cdot V(\lambda) \cdot d\lambda$$

where, $V(\lambda)$ = Relative Photopic Luminous Efficacy.

1.1.4. Reflectance

Reflectance is the ratio of the reflected radiant or luminous flux to the incident radiant or luminous flux,

$$\text{Luminous Reflectance: } \rho_v = \frac{\Phi_v^r}{\Phi_v^i}$$

$$\text{Spectral Transmittance: } \rho(\lambda) = \frac{\Phi^r(\lambda)}{\Phi^i(\lambda)}$$

where superscript "r" refers to reflected flux and superscript "i" to incident flux.

The total reflectance of an object (ρ) is divided into two parts: specular reflectance (ρ_s) and diffuse reflectance (ρ_d) where,

$$\rho = \rho_s + \rho_d$$

Specular reflectance consists of reflection of radiant or luminous flux without scattering or diffusing in accordance with the laws of optical reflection as in a mirror. Diffuse reflectance consists of scattering of the reflected flux in all directions.

As with photometric transmittance, the photometric reflectance of an object is dependent on the spectral composition of the radiating source and spectral composition of the radiating source must be known or specified when determining photometric reflectance. Also, as with photometric transmittance, photometric reflectance can be determined photometrically or spectroradiometrically.

1.1.5. Spectral Responsivity

Spectral responsivity, $R(\lambda)$, generally refers to the electrical signal generated by a photodetector ($s(\lambda)$) when irradiated with a known radiant flux of a specific wavelength ($\Phi(\lambda)$) and is determined using the relationship:

$$R(\lambda) = \frac{s(\lambda)}{\Phi(\lambda)}$$

The output signal of the detector can be in amperes, volts, counts/s, etc.

The spectral responsivity of a photodetector can be either a power response or an irradiance response. A power response generally involves under filling the detector with monochromatic flux, whereas an irradiance response involves uniformly overfilling the detector with monochromatic flux. It is possible to convert from one type of response to another if the area of the receiver (*sensitive portion of the photodetector*) is known and if the receiver is uniform in sensitivity.

1.2. SPECTRORADIOMETRIC STANDARDS

The accurate measurement of optical radiation involves not only the use of a stable, well characterized photometer, radiometer or spectroradiometer, but also, somewhere along the line, the use of a standard. This standard can be in the form of a radiating source whose radiant flux output and geometrical properties are accurately known, or a detector whose response is accurately known. For most spectroradiometric applications, a standard source should be used to calibrate the measurement system if the system is to be used to measure the spectral output of sources. A standard detector should be used to calibrate the measurement system if the system will be used to measure the spectral response of detectors. This section will describe the "basic" spectroradiometric standards which have been set up by NIST (*National Institute of Standards and Technology*) and which are available through commercial calibration laboratories. With the exception of blackbody standards, only those spectroradiometric standards suitable for use over the visible spectrum are covered.

In many instances, a "basic" spectroradiometric standard is no suitable for calibrating a measurement system. For example, it is

extremely difficult to use a "basic" spectroradiometric standard that has a nominal spectral irradiance of 0.1 [$W m^{-2} nm^{-1}$] to calibrate a measurement system that will be measuring irradiance levels that are 6 to 10 decades less. What is needed is a "special purpose," low-light-level standard that has an irradiance level comparable to the source to be measured. Accordingly, various "special purpose" spectroradiometric standards whose calibrations are based on the "basic" spectroradiometric standards will also be described.

1.2.1. Blackbody Standards

Since most of the spectroradiometric standards available for use over the visible spectrum are based on the spectral radiance of a blackbody as defined by the Planck Radiation Law, a short discussion on blackbody radiation is in order.

A blackbody is a theoretical source whose surface absorbs all of the radiant flux incident on it regardless of wavelength or angle of incidence, i.e. it is perfectly black (**6.7**). Planck's law defines the spectral radiance, L_λ , of a blackbody as:

$$L_\lambda = \frac{c_1}{n^2 \lambda^5 \left[e^{\left(\frac{c_2}{n\lambda T} \right)} - 1 \right]} \quad [W cm^3 sr]$$

where, $c_1 = 1st$ radiation constant ($3.7418 \times 10^{-12} W cm^2$)

$c_2 = 2nd$ radiation constant ($1.4388 cm K$)

$n =$ refractive index of air (1.00027)

$\lambda =$ wavelength in air (cm)

$T =$ thermodynamic temperature (K)

When radiant flux is incident on an object, it is either reflected (ρ), transmitted (ϑ), or absorbed (α) Thus,

$$\rho + \vartheta + \alpha = 1$$

If all of the energy incident on the object is absorbed, the absorptance is unity and, according to Kirchoff's Law (**8**), the emissivity of the object is also unity (**9**). In reality, a perfect absorber over all wavelengths and temperatures does not exist. There are a number of black paints, oxidized metals, and evaporated blacks that have an absorptance of 0.9 or better, but nothing close to unity. However, a near perfect absorber or emitter can be formed by placing a small hole in the wall of a hollow, isothermal enclosure whose interior surface has a high absorptance (≥ 0.9). Radiant flux incident on the opening of the enclosure is subject to the following:

- 1 Approximately 90% of the radiant flux incident on the surface is absorbed.

OPTRONIC™
LABORATORIES

Application Note: A14 Jan 2019

As part of our policy of continuous product improvement, we reserve the right to change specifications at any time.

- 2 The remaining 10% is diffusely reflected (provided that the interior surface of the sphere has a diffuse reflectance).
- 3 A negligible portion of the radiant flux will escape through the small opening on the first order reflectance.
- 4 Significantly smaller and smaller portions of the incident flux will escape through the opening for the higher order reflectances.

By careful design of geometry, choice of materials, and method of heating, a device can be constructed whose absorptance or emissivity is very close to unity. A number of methods exist for computing the effective emissivity of various radiating enclosures (10,11).

There are many commercially available blackbodies having various geometrical shapes and constructed of different materials for use over different temperature ranges. Some of these blackbodies are field portable and some are elaborate laboratory infrared standards that operate at the freezing temperatures of different metals. However, most of these blackbodies are used primarily in the infrared at wavelengths above about 1000 nm. Blackbodies suitable for use in the visible spectrum must operate at temperatures of 2500K or higher. These are extremely expensive devices and are not practical for normal laboratory calibrations.

1.2.2. Basic Spectroradiometric Standards

1.2.2.1. NIST Standard of Spectral Radiance

With the exception of a blackbody radiator, there were no convenient spectroradiometric standards prior to about 1960 (12). Although the blackbody was and still is the primary standard used for most infrared calibrations, its use in UV, visible, and near IR is very limited. The NIST scale of spectral radiance consists of a tungsten-ribbon filament lamp whose calibration is based on the radiant flux emitted by a blackbody of known temperature as determined from the Planck Radiation Equation (13,14,15). The originally lamp chosen by NIST was the GE30A/T24/3. It has a mogul bipost base, and a nominal rating of 30 A at 6 V. Radiant energy is emitted from the flat strip filament through a 1.25" fused silica window located in the lamp envelope. The window is parallel to and at a distance of about 3 to 4" from the plane of the filament. Spectral radiance values are reported over the wavelength range of 225 to 2400 nm. The estimated rms uncertainty varies with wavelength from 1.0% at 225 nm to 0.3% at 2400 nm and is about 0.6% throughout the visible spectrum. Typical spectral radiance values are shown in Table 1.3.

Tungsten ribbon-filament lamp standards of spectral radiance have found wide use in the calibration of spectroradiometric and other instrumentation used to measure the spectral radiance of a small area. However, the use of these radiance standards is limited by the small area that can be calibrated, and by the low radiance that the standards provide at lower wavelengths. These standards are useful when measuring the spectral radiance of plasmas, furnaces,

or other small area radiating sources. These radiance standards can also be used as an irradiance standard by carefully imaging the filament onto a small, precision slit with an accurately measured opening. The irradiance at a distance from the opening can then be calculated. However, a number of difficulties exist: the source area is quite small which limits the irradiance level; the effective transmittance or reflectance of the imaging optics must be measured; and the angular field is limited.

λ [nm]	L_{λ} [W cm ⁻³ sr ⁻¹]	T_{bb} [K]	λ [nm]	L_{λ} [W cm ⁻³ sr ⁻¹]	T_{bb} [K]
225	1.805	2677.3	575	97 830	2534.3
230	13.23	2677.1	600	113 700	2521.5
240	21.11	2676.3	654.6	147 300	2493.2
250	55.41	2674.7	675	158 600	2481.9
260	102.7	2672.9	700	171 800	2461.4
270	180.5	2671.0	750	194 000	2440.6
280	302.8	2669.1	800	211 800	2414.1
290	480.7	2665.4	900	229 000	2356.7
300	731.4	2662.2	1050	223 400	2269.4
325	1 867	2653.0	1200	198 100	2183.0
350	4 003	2643.0	1300	177 000	2125.9
375	7 540	2632.4	1550	127 300	1991.8
400	12 770	2620.8	1700	102 600	1916.3
450	29 100	2596.9	2000	66 390	1771.6
475	40 160	2584.6	2100	57 480	1736.0
500	52 880	2572.0	2300	42 780	1650.3
550	82 060	2546.8	2400	37 740	1611.1

Table 1.3 Measured Values of Spectral Radiance and Blackbody Temperature of a Tungsten Ribbon Filament Lamp



Figure 1.2 FEL spectral irradiance standard lamp and bipost system.

OPTRONIC™
LABORATORIES

Application Note: A14 Jan 2019

As part of our policy of continuous product improvement, we reserve the right to change specifications at any time.

1.2.2.2. NIST Standard of Spectral Irradiance

NIST established quartz-halogen lamps as standards of spectral irradiance in 1963 (16) in order to eliminate the problems associated with using the tungsten-ribbon filament lamp standards of spectral radiance. A GE 200-W quartz-iodine lamp was examined and found to have acceptable characteristics for use as a standard of spectral irradiance. It is a rugged lamp in a small quartz envelope of relatively good optical quality. The small size of the lamp envelope together with the small area of the filament yields an approximate point source irradiance field at fairly close distances, thus, permitting placing the lamp within 0.5 m of the spectroradiometer. The tungsten-halogen cycle permits operating the lamps at color temperatures as high as 3100K; thus, providing significantly higher irradiance levels in the ultraviolet spectral region. These new standards were calibrated over the wavelength range of 250 nm to 2500 nm. A similar 1000-W lamp was set up by NIST in 1965 relative to the 200-W standards. This standard had an irradiance level approximately 5 times that of the original 200-W standard. In 1975, NIST switched from the 1000-W DXW type lamp to a 1000-W FEL type lamp (17,18). These FEL lamps were converted to a medium bipost base which enabled more convenient use with a kinematic lamp holder, allowing the lamps to be removed and replaced exactly in the same position (see Figure 1.2).

Calibration of the FEL Standards of Spectral Irradiance is based on the NIST Standards of Spectral Radiance and is calibrated over the wavelength range of 250 nm to 2400 nm. Typical spectral irradiance values are given in Table 1.4. The estimated rms uncertainty varies with wavelength from 2.23% at 250 nm to 6.51% at 2400 nm and has an average uncertainty of about 1% in the visible.

λ [nm]	E_{λ} [W cm ⁻²]	λ [nm]	E_{λ} [W cm ⁻²]
250	0.182	550	101.7
260	0.320	600	137.5
270	0.531	654.6	161.6
280	0.833	700	190.3
290	1.258	800	221.9
300	1.830	900	231.6
310	2.592	1050	220.7
320	3.549	1150	203.0
330	4.752	1200	193.1
340	6.223	1300	173.3
350	7.998	1540	126.0
360	10.05	1600	166.9
370	12.46	1700	101.6
380	15.22	2000	67.1
390	11.31	2100	59.7
400	21.77	2300	46.0
450	44.06	2400	40.0
500	73.12		

Table 1.4 Spectral Irradiance of a 1000W FEL type lamp at 50 cm

1.2.2.3. NIST Standard Detector

NIST has established an absolute spectral responsivity scale based on a high accuracy cryogenic radiometer. Table 1.5 gives the estimated uncertainties assigned to selected silicon photodetectors calibrated relative to the NIST Scale. NIST also provides responsivity uniformity plots at specific wavelengths.

1.2.3. Special Purpose Spectroradiometric Standards

1.2.3.1. Spectral Radiance Standards with Sapphire Windows

This standard consists of a specially modified tungsten ribbon filament lamp (GE 18A/T10/2P) with an optical grade, sapphire window (19). These standards were developed in order to satisfy a need for a single radiance standard that could be used over the entire 250 nm to 6000 nm wavelength and also to provide an alternative to the more expensive and more difficult to obtain GE30A/T24/3.

The spectral radiance of these lamp standards with the sapphire window are traceable to the NIST Standard of Spectral Radiance over the wavelength range of 250 nm to 2400 nm and to blackbody calibration standard over the 2400 nm to 6000 nm wavelength range. The estimated rms uncertainty of these special purpose standards relative to the NIST Scale over the visible spectrum is 2%.

1.2.3.2. Spectral Irradiance Standards (1000 W DXW, 200 W, & 45 W)

A series of tungsten halogen lamps having wattages of 1000 W, 200 W and 45 W have been set up as special purpose standards of spectral irradiance (20). These standards are directly traceable to the NIST FEL Standard of Spectral Irradiance over the wavelength range of 250 nm to 2400 nm and to a blackbody calibration standard for wavelengths above 2400 nm. Whereas the spectral irradiance of the 1000 W DXW standard is similar to that of the FEL 1000 W standards, the 200 W and 45 W standards have irradiance levels of about 5 times and 20 times less than the 1000 W FEL standards respectively. However, all of these standards are calibrated when operating at a color temperature of about 3000k; thus, the relative spectral distribution is approximately the same for all of the lamps. The estimated rms uncertainty relative to the NIST Scale is on the order of 1% over the visible spectrum.

WAVELENGTH RANGE	UNCERTAINTY [%]
400 nm ≤ λ ≤ 440 nm	± 0.7
440 nm ≤ λ ≤ 900 nm	± 0.22
900 nm ≤ λ ≤ 1000 nm	± 0.3
1000 nm ≤ λ ≤ 1100 nm	± 0.7

Table 1.5 Estimated Uncertainty in Absolute Responsivity Measurements [This is a relative expanded uncertainty (k=2)]

1.2.3.3. Plug-In Tungsten Lamp Standards of Spectral Irradiance

Plug-in, pre-aligned irradiance standards (21) are available for accurately calibrating various spectroradiometers for spectral irradiance response (see **Figure 1.3**). These standards consist of a compact, 200 W tungsten halogen lamp operating at a color temperature of about 3000k. The short working distance of about 13 cm provides irradiance levels significantly higher than that normally obtained with higher wattage standards. The combination of greater precision in optical alignment and higher irradiance levels provides for a more accurate calibration of the spectroradiometer. The "plug-in/pre-aligned" concept also eliminates tedious and time consuming set-up and alignment that is normally associated with spectroradiometric standards as they merely attach to the integrating sphere input optics portion of the spectroradiometer. These standards have an estimated rms uncertainty relative to the NIST Scale of 1% over the visible spectrum.

1.2.3.4. Integrating Sphere Calibration Standards

All of the spectroradiometric standards described herein are calibrated for either spectral radiance or spectral irradiance and they are only calibrated for one set of conditions, i.e. one specified lamp current, one distance, etc. In addition, all of these standards, with the exception of the "plug-in/pre-aligned" standards, operate in the open air and cannot easily be attenuated. In many instances, there is a need for a large area, uniformly radiating source that is accurately calibrated for spectral radiance and, in some cases, calibrated for spectral irradiance. In addition, accurate attenuation of the radiance or irradiance of the source may be desirable. A carefully designed integrating sphere/tungsten lamp combination meets the above criteria.

Integrating sphere calibration standards generally consist of two parts: a source module/optics head and a separate electronic controller. The source module for a typical sphere source is shown in **Figure 1.4**. This unit incorporates a 150 W tungsten-halogen, reflectorized lamp with a micrometer controlled variable aperture between the lamp and the integrating sphere in order to vary the flux input to the sphere. The integrating sphere is coated with a highly reflecting, diffusely reflecting material such as PTFE or BaSO₄.



Figure 1.3 Plug-in pre-aligned standards of spectral irradiance.

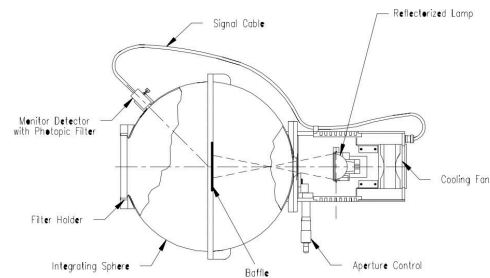

Figure 1.5 Sectional view of an integrating sphere calibration standard.

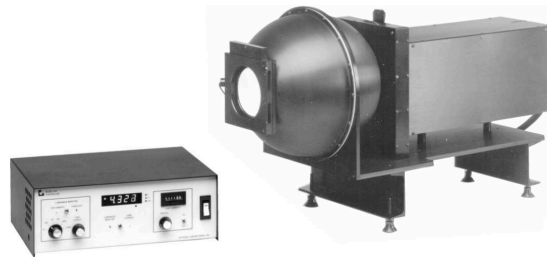

Figure 1.4 A low light-level integrating sphere calibration standard.

These materials have reflectances above 99% throughout the visible spectrum. The variable aperture at the entrance port of the sphere provides for continuous adjustment of the sphere radiance over a range of more than 10⁶. A precision silicon detector-filter combination with an accurate photopic response is mounted in the sphere wall and monitors the sphere luminance. The electronic controller contains the lamp power supply and the photometer amplifier. The source module/optics head is designed such that it can be configured with different sized integrating spheres; thus, the diameters of the exit (radiating) port can be made progressively larger as the sphere diameter increases. A 4:1 ratio of sphere diameter to exit port diameter will generally provide uniformity in the radiance at the exit port of $\pm 0.5\%$.

Since integrating sphere sources are quite uniform in radiance and have well defined radiating areas, the spectral irradiance can be computed once the source has been calibrated for spectral radiance. It should be noted that these integrating sphere sources are also used quite extensively as photometric standards. In general, the detector/photopic filter that serves as a monitor in the sphere wall is calibrated such that the luminance of the sphere is displayed on the electronic controller.

A sphere source of this design that incorporates a 4" diameter integrating sphere will typically have a 1" diameter radiating port with an adjustable luminance from 100,000 cd/m² to 0.001 cd/m². A 12" diameter version will have a 3" diameter radiating port with an adjustable luminance from 12,000 cd/m² to 0.001 cd/m². Typical estimated uncertainties are 2% rms relative to the NIST Scale.

For measurement application requiring even lower output levels than that obtainable with the sphere source described above, an extremely low-light-level integrating sphere source such as that shown in **Figure 1.5** is available. This source is similar to that described above, but two methods are used to attenuate the sphere radiance without changing the spectral distribution of the source. A low wattage tungsten-halogen is mounted on a moveable track such that the distance from the lamp to the entrance port of the sphere can be varied from 5 to 30 cm. Immediately in front of the entrance port of the sphere is a 6-position aperture wheel containing precision apertures having diameters from 28 to 0.15 mm. Thus, the combination of varying the lamp-sphere distance and inserting different sized apertures over the entrance port enables precise setting of the radiance/luminance of the radiating port. This integrating sphere source is also designed such that the optics head can accommodate different size spheres. Luminance levels as low as 10^{-5} cd m⁻² can be obtained with this version.

In some cases, it is desirable to have even larger radiating areas than that obtainable with the integrating sphere sources described above. In these instances, integrating spheres having diameters of 30" or greater are available. These sphere sources generally have one or more lamps mounted inside the sphere. Attenuation is accomplished by turning one or more of the lamps off.

In general, spectral radiance values for integrating sphere calibration standards are reported for a specified lamp current. Varying the operating current not only changes the magnitude of the spectral radiance, it also changes the spectral distribution. Thus, it is imperative that the lamp be operated at the specified current when used as a spectroradiometric standard. However, this is not the case when these integrating sphere sources are used as photometric standards. The silicon detector/photopic filter monitor will measure luminance and the accuracy of the luminance display is not dependent on the lamp current provided that the detector/filter is accurately matched to the CIE photopic efficacy function.

1.2.3.5. Detector Spectral Response Calibration Standards

Silicon photodiodes are available having spectral responsivity calibrations in terms of power response or irradiance response over the wavelength range of 200 to 1100 nm (**22-25**). These calibrated detectors generally have a 1 cm² active area and are mounted in black anodized, aluminum housings with a convenient BNC connector. They may also include a removable precision aperture. **Figure 1.6** shows a typical spectral responsivity plot (power response in A/W).

The photodetectors are normally calibrated with zero bias voltage (short-circuit mode). The transfer uncertainty in the calibration of these detectors relative to the NIST scale is on the order of 0.5% over the visible spectrum.

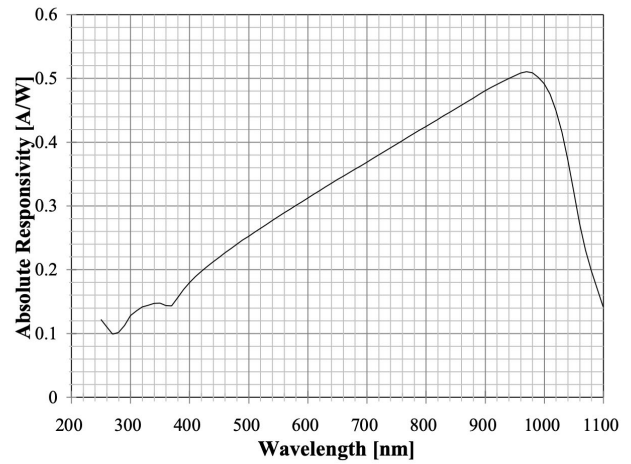

Figure 1.6 Spectral Responsivity of a Typical Silicon Photodetector.

1.3. SPECTRORADIOMETRIC INSTRUMENTATION - GENERAL

At the heart of any spectroradiometer is some mechanism for separating the optical radiation into its spectral components (**26,27**). By far the best and most common mechanism is a monochromator. This section will review the components of the monochromator, their role in determining the performance of the system as a whole, and the typical specifications that users should look for when selecting a system.

A typical monochromator, such as those shown in **Figures 1.13, 1.14 and 1.16 to 1.18**, consists of entrance and exit slits, collimating and focusing optics, and a wavelength dispersing element such as a grating or prism. Additional mechanisms such as optical choppers or filter wheels may be included, and are often mounted inside the monochromator.

1.3.1. The Wavelength Dispersing Element

Most modern monochromators use diffraction gratings, but a few of the older prism-based monochromators are still in use. Diffraction gratings have a few disadvantages when compared to prisms (mainly the multiple-order effects covered later), but their greater versatility, ease of use, wavelength range and more constant dispersion with wavelength means that grating monochromators are used almost exclusively in spectroradiometry. Since grating monochromators are by far the most widely used, further discussion will exclude the other types.

1.3.2. Collimating and Focusing Optics

The first optical element of a monochromator is usually a collimating optic (typically a concave mirror), which alters the diverging beam coming from the entrance slit into a collimated beam directed at the grating. The grating acts on this incident collimated beam to create a series of collimated diffracted beams, each at a different angle that depends on wavelength. By rotating

the grating, each wavelength in turn will strike the focusing optic, creating an image of the entrance slit at the exit slit position. In some monochromators, the use of collimating and focusing optics is eliminated by employing curved gratings (as shown in **Figure 1.11**). These are generally more compact than plane-grating monochromators but are limited in wavelength range because the gratings are no longer interchangeable.

1.3.3. The Wavelength Drive Mechanism

When rotating the grating, two main drive mechanisms are currently used: direct and sine-bar. Sine-bar mechanisms essentially convert the sine function dependence between grating angle and wavelength to a linear drive mechanism giving a constant number of steps (*of a stepper motor*) per unit of wavelength. This type of mechanism was employed in most old-style monochromators since it provides easy connection to a mechanical counter showing the wavelength selected, and hence may be used in “manual” systems. As technology advanced, reliable self-calibrating monochromators were developed, eliminating the need to read the counter before use. By eliminating the counter, the need for sine-bar drives was also removed, allowing direct drive mechanisms (*giving a constant number of steps per grating angle change*) to be introduced. Direct drive mechanisms can be thought of as having a “theoretical” sine-bar, where the angle necessary to give the correct wavelength is calculated and then selected. The elimination of the sine-bar mechanism removes many of the associated errors and in some cases allows grating turret and wavelength drive mechanisms to be combined.

1.3.4. Stray Light

Although monochromators are used to isolate a particular spectral component from all other wavelengths, any practical monochromator will transmit residual “out-of-band” wavelengths and this is known as stray light. For most visible applications, this effect is virtually negligible but for certain usage, such as measurements for night-vision systems, this stray light can swamp the real spectral components being analyzed. In such cases, a double monochromator is used to reduce the typical 10^{-4} stray light levels to 10^{-8} (*expressed as the ratio of detected stray to the total detectable radiation entering the monochromator*). A double monochromator is essentially two identical single monochromators where the output of the first is the input of the second. Naturally, for this to work both monochromators have to be set to the same wavelength, and experience has shown that the only way to achieve reliable results is to have both monochromators sharing the same base-plate and drive mechanism. Attempts at bolting two single monochromators together have been tried many times in the past (*and sometimes at present*) with poor results, and this approach should be avoided.

1.3.5. Blocking Filters

Since gratings disperse light by diffraction, any wavelength of light may be diffracted in several directions (*orders*) as shown in **Figure 1.7**. In practice, this means that the first order of 900 nm

is diffracted at the same angle as the second order of 450 nm and the third order of 300 nm. When measuring light at 900 nm it is therefore essential to remove the 450 nm and 300 nm components, and this is done by blocking filters. Blocking filters absorb short wavelengths while transmitting long wavelengths. For example, a 550 nm blocking filter would absorb both the 450 nm and 300 nm components while leaving the 900 nm essentially unaffected. In visible applications, at least two blocking filters are generally used: the first to block any UV components and the second to prevent 380 nm light recurring at 760 nm. These filters are placed in the beam at the appropriate wavelengths during a scan, and are often placed within a filter wheel and selected automatically, making the entire process “transparent” to user.

1.3.6. Grating Optimization

The grating consists of many finely spaced lines (*or grooves*) etched into a surface. The density of these grooves, expressed in grooves per millimeter ($g\text{ mm}^{-1}$) determines the angular separation of wavelengths (*dispersion*) in any monochromator. Also, by altering the shape of the groove profile, it is possible to make certain angles of diffraction more efficient. This process is known as blazing, and is used to increase the throughput of the monochromator in desired spectral regions. However, this process also decreases the throughput outside of this region, giving the normal “rule-of-thumb” that the usable wavelength range of a grating is two-thirds to twice the blaze wavelength. For example, a grating blazed at 500nm should be usable from 330nm to 1000nm, and in practice this is almost always selected for visible work. Other gratings can be chosen to increase the accuracy for specific sources (*very blue or red*), but the close agreement of maximum efficiency with the peak of the photopic response function makes the 500nm blaze grating the best choice for general applications.

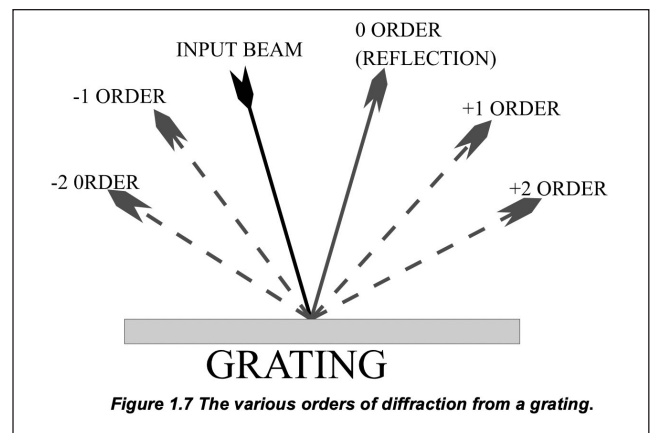

1.3.7. Detectors

Although the monochromator is at the heart of any spectroradiometer, a detector is always present in the system. The choice of detector is generally dictated by the light levels to be measured, the stability required, and any non-visible application that the system may be required to perform. Almost all spectroradiometers use one of two types of detectors for visible work: a silicon photodiode or photomultiplier tube (PMT). The silicon photodiode may be used in most medium-to-high light level applications, and the PMT is used at low light levels. Silicon photodiodes can vary in their usable wavelength range, but virtually all respond to visible wavelengths. On the other hand, PMTs vary considerably in their usable range, and only trialkali (S20) or gallium arsenide PMTs are routinely used in photopic applications. The S20 PMTs respond to wavelengths up to 830nm, which is adequate for normal photopic applications, whereas gallium arsenide PMTs are chosen for night vision tests because of their longer wavelength response of up to 930 nm.

1.3.8. Signal Detection Systems

In many cases, the electronics to amplify and process the signals from the detector, commonly referred to as signal detection systems, influence the performance of the system. For instance, DC amplifiers able to resolve currents from silicon detectors of about 10^{-12} A (1 picoamp) are readily available from most manufacturers, but some suppliers offer much superior performance (to 10^{-15} A, or 1 femtoamp). Since the inherent noise of a silicon detector at room temperature is about 10^{-15} A, anything but the best amplifiers will both decrease the sensitivity range and increase the noise of the detection system. The noise and sensitivity of a PMT depends both on the PMT voltage and the type of signal detection system. In DC amplification mode, the dark current of an S20 PMT is, at best, in the picoamp range at room temperature. The amplifier does not therefore require sensitivity ranges less than this but should still be of good quality to prevent adding noise unnecessarily.

Lock-in amplification, also referred to as AC amplification, can also be used with both PMTs and silicon detectors. Here, an optical chopper spins to alternately transmit and block light at frequencies of tens to hundreds (or even thousands) of cycles per second (Hertz). An amplifier, locked in to the chopping frequency, gives a signal proportional to the difference between light and dark phases of the cycle. This technique can be used to eliminate those components that are not at the chopping frequency, such as most of the noise, and compensates for dark current drifts in the system. However, like any other amplifier, lock-in amplifiers can also add noise to the signal and are most useful when used with infrared detectors rather than the relatively noiseless visible detectors such as silicon detectors and PMTs.

Photon counting (PC) signal detection systems provide greater sensitivity than DC or AC modes but are limited to PMTs. PC detection systems for silicon photodiodes have been developed (28) and are commercially available, but can only be used with detectors too small for practical spectroradiometric use. In PC mode, each photon hitting the photocathode of the PMT produces

a current pulse. These pulses are separated from the large number of smaller pulses from the rest of the PMT and counted. The result is a system that actually counts the individual photons that are absorbed by the PMT. Since a photon is the smallest quantity of light (*equivalent to an atom of an element*) this represents the ultimate theoretical sensitivity achievable.

1.3.9. Monochromator Throughput and Calibration Factors

When making spectroradiometric measurements, the factors relating the intensity of light at each wavelength to the signal observed must be determined. In theory, if the contribution of each component in the system is known, these factors can be calculated. However, in practice this yields no more than "a rough estimate." To determine the exact factors, a calibration standard (*where the intensity of light is known at each wavelength*) is used. These calibration standards should be traceable to NIST or other national standards laboratory to ensure correct results.

1.3.10. Slits and Aperture Selection

Selection of appropriate slits and apertures is critical in obtaining correct spectroradiometric results and yet remains a subject fogged in mystery for most users. This section aims to help dispel that fog, giving the user a clear insight as to which slits or apertures should be selected for their particular application.

Monochromator slits are rectangular, generally much taller than they are wide, and are positioned so that the long side is normal to the plane of the monochromator (*i.e. usually vertical*). An aperture may be any shape, though it is usually circular, and is used in place of a slit in certain applications. For the purpose of this discussion, circular apertures will be assumed, since these are the most common and represent a very different shape than that of a slit.

Input or exit optics will frequently require a circular aperture to define a field-of-view (*telescopes, microscopes and other imaging optics*), the beam convergence/divergence and uniformity (collimating optics), or the size of an image (*some reflectance, transmittance or detector response accessories*). Generally, the only accessories that do not require apertures are non-imaging types such as integrating spheres. **The requirements of the input/exit optics always determine the selection of an aperture or slit.** If the accessory attached to the entrance requires an aperture, then it is installed in place of the entrance slit; if the accessory attached to the exit requires an aperture, then it is installed in place of the exit slit.

Theoretically, two apertures may be installed - at both the entrance and exit slits. However, such a configuration requires exact alignment of heights and is subject to large changes in throughput with small changes in temperature, flatness of benches

OPTRONIC™
LABORATORIES

Application Note: A14 Jan 2019

As part of our policy of continuous product improvement, we reserve the right to change specifications at any time.

etc. This inherently unstable arrangement is therefore rarely used, except in special applications, and generally whichever side of the monochromator that is opposite the accessory should always have a slit installed.

1.3.10.1. The Concept of Limiting Aperture

For large sources or non-imaging optics, the entrance aperture (or slit) limits the size and distribution of light entering the monochromator. However, for certain other applications, the size and distribution may be limited by other factors, making the selection (or indeed the presence) of the slit or aperture irrelevant.

In certain applications, e.g. spectral radiant intensity measurements, the aperture must be under-filled. This means that the aperture no longer defines the size or shape of the image entering the monochromator. An "equivalent aperture" having the same size and shape as the image should then be used to determine the expected behavior of the system.

Similarly, when using fiber optics (even slit-shaped fibers) the slit width or aperture only applies when smaller than the fiber. If the fiber is smaller than the slit (or aperture) it is the fiber that determines the expected behavior of the system. When using a light source that forms an image of the source onto the entrance slit, the same considerations apply.

The concept of limiting apertures can also be applied at the exit of a monochromator, since detectors may be small, e.g. a 5 mm slit is the limiting aperture when using a 10 x 10 mm silicon detector, but not when using a 3 x 3 mm PbS detector. Even if the detector is coupled to the monochromator using imaging optics, it may still define a limiting aperture once magnification effects have been considered.

1.3.10.2. Slit-slit Bandpass and Slit function

When using a monochromatic source, the monochromator forms an image of the entrance slit at the exit. The exit slit therefore acts as a mask, defining the portion of the image that reaches the detector. As the wavelength is altered, the image moves across the exit slit, and a scan of detector signal versus wavelength is called the slit function and may be used to find the full-width-at-half-maximum (FWHM) or, as it is more commonly called, the bandpass.

The slit function, and hence bandpass, can be calculated quite simply for an ideal instrument. Two possible shapes exist: one where the entrance and exit slits are the same, and the other where they are different. If the detector responds equally to all light passing through the exit slit then, as illustrated in **Figure 1.8**, the signal is proportional to the area of overlap between the image of the entrance slit and the mask formed by the exit slit. This gives a triangular slit function for equal slits, and a flat-topped function for different slits. In the case of different slits, the image could be wider than the exit slit and still give the same result, so the slit function is independent of which slit is the entrance and which is the exit.

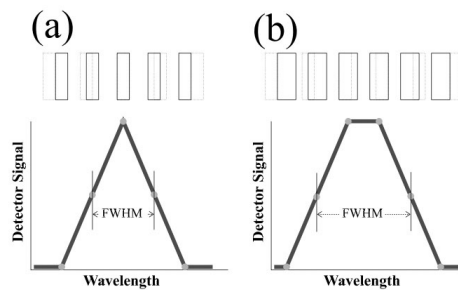

Figure 1.8 Slit function and bandpass for (a) equal slits and (b) different slits. In each case, the detector signal is proportional to the overlap between the image (dashed line) and the exit slit (solid line).

Although these two shapes exist, in fact only one is sensible for spectroradiometry: equal slits. This is because with different slits the throughput (and hence signal) is limited by the smaller slit while losing resolution to the wider slit, and severe sampling errors can arise in measurements of sharp spectral features with normal scan intervals. On the other hand, equal slits provide the maximum signal at any bandpass and give accurate peak areas with most scan intervals less than the FWHM.

In a real system, the triangular function will have a rounded top and baseline intercept. Also, if the slits are very narrow, the function may often resemble a skew-Gaussian curve rather than a triangle. These are due to normal aberrations found within any monochromator system and do not affect the general principles outlined.

1.3.10.3. Aperture-slit Bandpass and Slit function

As with slit-slit systems, an image of the entrance aperture is formed at the exit slit, though the resulting slit function is not nearly so obvious. The important difference for aperture-slit calculations is that the shapes are sufficiently mismatched to create three possibilities for the slit function, as shown in **Figure 1.9**. The first (a), where the aperture is much larger than the slit, gives a cosine-curve shaped slit function. The second (b), where they are the same width, gives an almost triangular shape (except the sides are "S-shaped") with essentially the same bandpass as the slit-slit equivalent. The third option (c), where the aperture is much smaller than the slit, gives a flat-topped profile with "S-shaped" sides.

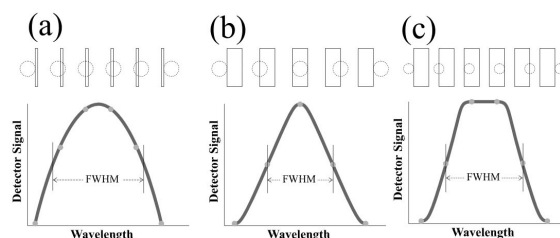

Figure 1.9 Slit function and bandpass for (a) aperture much bigger than slit, (b) aperture same width as slit and (c) aperture much smaller than slit. In each case, the detector signal is proportional to the overlap between the image (dashed line) and the exit slit (solid line).

For exactly the same reasons as those applying to slit-slit configurations, best results are obtained by matching the slit and aperture widths as closely as possible. However, since the size of the aperture and slit are normally determined by additional factors such as field-of-view and sensitivity, it is not unusual to make measurements with the slit larger than the aperture. There are no circumstances where slits much smaller than the aperture give better results than matched combinations.

Although the above description used a aperture entrance and slit exit, the same results would be obtained if they were reversed since we are treating the monochromator as ideal. In real systems, very slight differences may exist between the two configurations since aberrations will distort the images of slits and apertures differently.

1.3.10.4. Dispersion, Bandpass and Limiting Resolution

The previous section dealt with the shape of the slit function. However, to put actual values to the bandpass the dispersion must also be known. The dispersion (*or more correctly inverse-linear-dispersion*) is the wavelength region (*in nm*) in 1mm distance in the plane of the slit. It varies with the focal length of the monochromator and the grating groove density (*grooves per millimeter*). For any particular monochromator, if the dispersion with a 1200 g/mm grating is known (*this is usually available from the manufacturer*), the bandpass with any grating or slit width can be calculated using:

$$B = \frac{1200 \cdot D \cdot S}{G}$$

where: B is the bandpass in nm

D is the dispersion in nm/mm with a 1200 g/mm grating

G is the groove density of the grating used in g/mm

S is the slit width in mm.

ENTRANCE SLIT [mm]	EXIT SLIT [mm]				
	0.25	0.5	1.25	2.5	5.0
0.25	1.0	2.0	5.0	10.0	20.0
0.5	2.0	2.0	5.0	10.0	20.0
1.25	5.0	5.0	5.0	10.0	20.0
2.5	10.0	10.0	10.0	10.0	20.0
5.0	20.0	20.0	20.0	20.0	20.0

Table 1.6 Bandpasses (in nm) for various slit-slit combinations for a single monochromator with 4 nm/mm dispersion. Recommended combinations are highlighted.

Thus, if a 600 g/mm grating is used with a monochromator of 4 nm/mm dispersion and 1.25 mm slits, the bandpass will be 10 nm. **Table 1.6** shows the bandpasses of various slit-slit combinations (*for a single monochromator with 4 nm/mm dispersion*), highlighting the recommended (*equal entrance and exit*) selections.

The above equation is based on two basic assumptions: that the

dispersion remains constant with wavelength and is perfectly linear at all slit widths. Real systems have a variable dispersion with wavelength, though good designs can optimize this to just a few percent, and aberrations and alignment errors generally limit the bandpass at small slit widths. This limit at small slit width is called the limiting optical resolution of the system. Spectroradiometric measurements are generally made at bandpasses well above the limiting optical resolution of the system to ensure that the slit function is reasonably constant at all wavelengths.

Because the slit function changes with the relative size of the aperture-slit combinations, mismatches (*even to smaller widths*) can lead to increased bandwidths. This means that the above formula for slit-slit combinations will not apply to aperture-slit sizes. **Table 1.7** shows the bandwidths of various aperture-slit combinations (*for a single monochromator with 4 nm/mm dispersion*), with the recommended configuration highlighted

APERATURE DIAMETER [mm]	EXIT SLIT [mm]				
	0.25	0.5	1.25	2.5	5.0
1.5	3.8	3.6	4.0	7.5	15.0
3.0	7.7	7.6	7.3	1.1	15.0
5.0	13.0	12.9	12.3	12.2	15.0

Table 1.7 Bandpasses (in nm) for various aperture-slit combinations for a single monochromator with 4 nm/mm dispersion. Recommended combinations are highlighted.

1.3.11. Throughput versus Bandpass

Optimizing practical measurements often involve a trade-off between smallest bandpass and highest signals. If there are fixed parameters, such as field-of-view, that must be observed, the slit/aperture configuration will also be fixed. However, if several combinations are possible, then the system may be optimized. Assuming that the slits and apertures are matched, as recommended, and the entrance slit (*or aperture*) is uniformly illuminated, the signal increases with width. The magnitude of this increase varies with the type of source and whether slit-slit or aperture-slit combinations are used.

If the source is a broad-band type, such as a tungsten lamp, doubling the slit-slit sizes would double both the intensity entering the monochromator and the bandpass of the system: giving a four-fold increase in signal. Under the same conditions, an eight-fold increase would be seen for aperture-slit combinations, since both width and height of the aperture are doubled.

When a monochromatic source such as a mercury lamp is used, only a two-fold and four-fold increase is seen for the respective slit-slit and aperture-slit combinations because only one wavelength

component exists. This difference between monochromatic and broadband sources accounts for the observed changes in the spectra of mixed sources, such as fluorescent lamps, as the bandpass is altered. In such a case, as the bandpass is decreased, the peaks due to the monochromatic lines become much “taller” in proportion to the broad emission of the phosphors.

1.3.11.1. Double Monochromators and Middle Slits

The above sections deal with entrance and exit slits and apertures for a single monochromator. The basic principles apply also to double monochromators, but with modifications. Essentially, a double monochromator is two identical single monochromators working in series but using a single drive mechanism and housing. Theoretically, and sometimes practically, double monochromators have four slits - an entrance and exit for each of the single monochromator components. More generally, the exit of one is the entrance of the other and hence only three slits are used - the entrance, middle and exit. The influence, and hence selection, of the middle slit largely depends on whether the double monochromator is additive or subtractive.

The majority, by far, of double monochromators in use are additive. Additive means that light that is dispersed by the first monochromator component is further dispersed by the second. Thus, if a single monochromator has a dispersion of 4 nm/mm, then a double additive monochromator of the same basic design would have a dispersion of 2 nm/mm. When using **Tables 1.6 and 1.7** for the equivalent additive double monochromator systems, the bandpass calculated should be divided by 2. However, even though both monochromator components share the same drive and housing, links and gears can mean that each part may not transmit exactly the same wavelength (*this is commonly referred to as “coordination” of the monochromators*). If this happens, the throughput of the system will suffer, and if this wavelength mismatch is temperature dependent (*as it is in all practical systems*) then it is inherently unstable and unsuitable for spectroradiometry. Compensating for this is actually quite easy: the middle slit should be at least 1 to 2 mm bigger than the entrance and exit whenever possible. Apertures are **never** used in the middle slit position.

Subtractive monochromators have two main applications. The first of these is performing extremely fast measurements, of the order of picoseconds. Here, the difference in path lengths through an additive monochromator might spread out a pulse because of the finite speed of light, but the symmetrical arrangement of a subtractive double monochromator provides a constant length for all paths. The second application, for measurements such as detector spectral response, is more common. In additive double monochromators, the small difference in wavelength between the left and right edges of the slit can cause serious errors if the detectors are not uniform. However, the subtractive double monochromator has no residual dispersion at the exit slit, eliminating this source of error. The lack of residual dispersion is because the second component monochromator operates, not to further disperse like an additive system, but to combine (*the*

opposite of disperse in this context) any light dispersed by the first component monochromator. This means dispersion effectively only occurs in the first component monochromator, and this system should be treated as a single monochromator using the entrance and middle slits as far as slit function, bandpass etc. is concerned. However, the coordination of the two components is still important, and since there is no effective movement of the image at the exit slit, it is prudent to:

- i. have the entrance slit slightly larger than the exit slit (*or aperture*).
- ii. have the middle slit slightly larger than the entrance slit.

These conditions are to optimize stability, which is essential for good spectroradiometry, but they do compromise the narrowest bandpasses and triangular slit function. If a triangular slit function is required, equal entrance and middle slits should be chosen. If the narrowest bandpass is also desired, then the entrance and middle slits should be equal to the exit slit/aperture (*but beware of the inherent instability of such an arrangement*).

1.4. PERFORMANCE SPECIFICATIONS

Having described the function and use of each component of a spectroradiometer in section 1.3, it is worthwhile considering typical specifications of a system and how these affect results.

1.4.1. f-number

The f-number of any focusing system is the focal distance divided by the limiting aperture. It is therefore inversely related to the solid angle encompassed by, and hence the “light-gathering power” of, the optical system. In other words, the smaller the f-number, the greater the throughput of a monochromator. However, there are practical limits to the f-number for monochromators. Since spherical mirrors are generally used in monochromators, instead of the ideal off-axis paraboloid shape, at f-numbers less than 3 or 4 the aberrations destroy the advantages of decreased f-number. Also, monochromators are almost always used with accessories appropriate to the type of measurement, and these accessories generally have larger f-numbers than the monochromator, thus limiting the overall system. For most applications, the best compromise is obtained by selecting a monochromator with an f-number of about 4.

1.4.2. Wavelength Accuracy / Resolution / Repeatability

When a monochromator selects a wavelength, there may be a difference between the actual wavelength transmitted and that reported by the computer or wavelength counter. The wavelength accuracy required largely depends on the application and how fast the signal changes with wavelength, but for general photopic

OPTRONIC™
LABORATORIES

Application Note: A14 Jan 2019

As part of our policy of continuous product improvement, we reserve the right to change specifications at any time.

applications the monochromator should always be within ± 0.2 nm of the true wavelength. Some manufacturers now use a polynomial fit (also known as a cubic spline) to improve the accuracy, and this should be adopted whenever available.

As the slit widths are reduced, eventually a limiting bandpass is reached. This is the limiting optical resolution of the monochromator. For photopic, and indeed most other spectroradiometric measurements, bandpasses of less than about 0.5 nm are rarely used. This is readily achievable with a 250 mm focal length monochromator, which is probably the most usual instrument found in spectroradiometric laboratories. To scan sources containing monochromatic emission or absorption lines, such as fluorescent lamps, greatest accuracies are achieved with bandpasses of 1 nm or less. However, when scanning at these small bandpasses it should be borne in mind that at least two (*and preferably five or more*) data points per bandpass should be obtained. The monochromator should therefore have a step resolution (*the smallest increment of wavelength movement*) of one-fifth or less of the limiting optical resolution to accommodate all possibilities, and the user should realize that accurate measurements of line sources take more data points than broadband sources.

Obviously, to obtain accurate results the monochromator must transmit the same wavelength each time it is selected. In practice, small pseudo-random variations are found. To be reliable enough for spectroradiometric measurements, this variation - the reproducibility - needs to be about ± 0.1 nm or less.

1.4.3. Bandpass

To allow for the various applications and sources encountered in spectroradiometric measurements, the monochromator should normally allow bandpasses of 0.5 nm to 20 nm (*or more*) to be selected. The bandpass depends on the monochromator dispersion, and for a value of 4nm/mm this corresponds to slits of 0.125 mm to 5 mm.

1.4.4. Sensitivity and Dynamic Range

The $V(\lambda)$ function values vary by over 6 decades, depending on wavelength. In order that a source is properly represented, this then is the minimum required dynamic range of a spectroradiometer for photopic measurements. Many broadband sources, such as tungsten lamps, may not require measurements over a wide range of signals, but others such as red LEDs certainly do. As an illustration, consider an extreme example of an LED with a maximum intensity emission at 830 nm. The $V(\lambda)$ value at 830 nm is 4.52×10^{-7} , which means that any emission at 555 nm from this LED will contribute over 2 million times that of the peak value towards the final photopic result. If the dynamic range of the instrument is unable to resolve this level of emission, the user will be unable to provide an accurate photopic value. To resolve this, the instrument must be sensitive enough to detect any light at 555 nm, and yet still accommodate the peak intensity nearly 7 decades stronger.

The dynamic range of an instrument, being the ratio of the largest measurable signal to the smallest, is a relative measure of performance. It is not, in itself, an indication of quality. For instance, in the above example a range of 10^{-10} to 10^{-3} A would not be sufficient for accurate measurements if the signal at 830 nm was 10^{-7} A, since the higher ranges are redundant.

The smallest measurable signal is generally determined by digitization or noise, whichever is greater. Noise is a random variation of signal with time whereas the digitization limit is the difference between 0 and 1 of the analog-to-digital or similar converter (*also often referred to as the signal resolution*). Although this noise is electrical, it can be expressed in terms of an equivalent intensity of light. Noise equivalent power (*NEP*), noise equivalent irradiance (*NEI*), noise equivalent radiance (*NER*), etc. are used to specify the smallest signals measurable for most spectroradiometric systems. This parameter not only serves to place the dynamic range on an absolute scale, but also indicates the overall performance of the system since it depends on throughput of the monochromator and the quality of the detector and electronics. However, care should be exercised in comparing specifications from two manufacturers since this parameter varies with wavelength and conditions of measurement.

1.4.5. Stray Light

Stray light can be thought of as a limit to measurements of weak spectral components in the presence of strong spectral components. For instance, in the LED example above, if the stray light level was 10^{-4} then the signal measured at 555 nm may be only two or three decades below that at 830 nm - even if there is no light at 555 nm. In such a case, the photopic value calculated would be grossly in error, despite the signal being well above the noise-equivalent-input of the detector and within the dynamic range of the system.

As already pointed out, many photopic applications require stray light levels of around 10^{-4} to achieve accurate results. Some applications, e.g. NVIS or the LED example above, require much lower stray light levels than this. Alternatively, if other measurements are performed with the same instrument, such as UV hazard assessment, this may dictate this selection of the instrument. For these more stringent applications a double monochromator with stray light levels of $\leq 10^{-8}$ are used.

It is always acceptable to use a monochromator with low stray light for less stringent applications, but never vice versa.

1.4.6. Scanning Speeds

It is not unnatural for users to want faster and faster scanning. However, the correct balance between speed and accuracy must

OPTRONIC™
LABORATORIES

Application Note: A14 Jan 2019

As part of our policy of continuous product improvement, we reserve the right to change specifications at any time.

be found. Certainly, scans may be speeded up by not selecting blocking filters, not changing gain ranges, and integrating signals for a short time, but results may become meaningless with this approach. Also, one should not confuse slow scans with slow systems. Often a slower instrument will move the monochromator, change filters and gain ranges just as fast as a faster one - the difference is the time and care spent in measurement.

1.4.7. Stability

To be effective, a spectroradiometer must be stable over the time between calibration and measurement. Although some drift in the electronics would normally be expected, much of this is removed periodically by such routines as self-calibration and dark-level subtraction. The largest influence on the stability of spectroradiometers is the environment and treatment of the instrument. In fact, the interval between recalibrations is often more dependent on the environment than on the instrument. Movement and temperature changes should be kept to a minimum to maintain calibrations for as long as possible. Also, regular checks on the wavelength and throughput (*using appropriate standards*) should be made to track changes in calibration factors, and hence predict when recalibrations are necessary to maintain the desired accuracy.

1.4.8. Software and Automation

Although this is not a specification as such, in that it only has a secondary influence on results, the degree of automation found in current systems results in the software, and not the user, often determining the methods of measurement and calculation. The user should therefore verify that the techniques dictated by the software are appropriate.

1.5. SPECTORADIOMETRIC MEASUREMENT SYSTEMS.

The components essential to a spectroradiometer have been discussed in section 1.3. In addition, front end or input optics that collect and transfer the incident optical radiation into the measurement system are needed when measuring the spectral output of various light sources, and both input and exit optics are required when measuring spectral transmittance, spectral reflectance, or spectral response of photodetectors. However, in all cases, proper calibration of the measurement system with the appropriate spectroradiometric standard is essential. This section will cover:

- 1 The selection and use of various input/exit optic modules; and
- 2 The selection and use of the appropriate standard to calibrate the integrated measurement system.

1.5.1. Source Measurements/Input Optics/System Calibration

1.5.1.1. Spectral Irradiance & Radiant Flux / Cosine Collectors

Cosine collectors sample radiant flux according to the cosine of the incident angle. These devices accept radiation from the entire hemisphere. Two general types of cosine collectors are available: transmitting or reflecting type diffusers. Reflecting type diffusers are vastly superior with respect to both cosine collection

and wavelength range of usefulness. The predominant reflecting cosine collector used for optical radiation measurements is the integrating sphere.

A properly designed and coated integrating sphere (see **Figure 1.10**) is extremely useful for many photometric, radiometric, and spectroradiometric measurements. Integrating spheres can be obtained with various geometries and with different coatings. A prerequisite for a good integrating sphere is a diffuse, highly reflective coating. The sphere geometry and type of coating used depend on the measurement application. BaSO₄ and PTFE based coatings have reflectances approaching 100% in the visible spectrum.

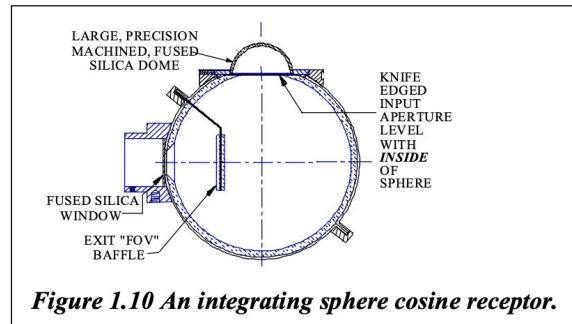

Figure 1.10 An integrating sphere cosine receptor.

Integrating spheres are particularly useful when measuring the spectral irradiance of large or irregularly shaped sources and are essential when measuring the irradiance of sunlight, fluorescent lamps, or any other large area or extended source. Integrating spheres are also quite useful when measuring the luminous, radiant, or spectral radiant flux of diverging or diffusely radiating sources. In such cases, all of the flux emitted by the source must be collected at the entrance port of the sphere. **Figure 1.11** shows an integrating sphere cosine collector mounted at the entrance slit of a double grating monochromator.

Calibration of a spectroradiometer with an integrating sphere input is accomplished using a standard of spectral irradiance. The "plug-in/pre-aligned" standard of spectral irradiance described in Section 3.1 is particularly well suited for this application. The spectral irradiance response function, $\Psi(\lambda)$, of a system is determined from the relationship:

$$\Psi(\lambda) = \frac{E(\lambda)}{s(\lambda)}$$

where, $E(\lambda)$ = Spectral Irradiance of Calibration Standard
 $s(\lambda)$ = Photodetector Signal at each Wavelength

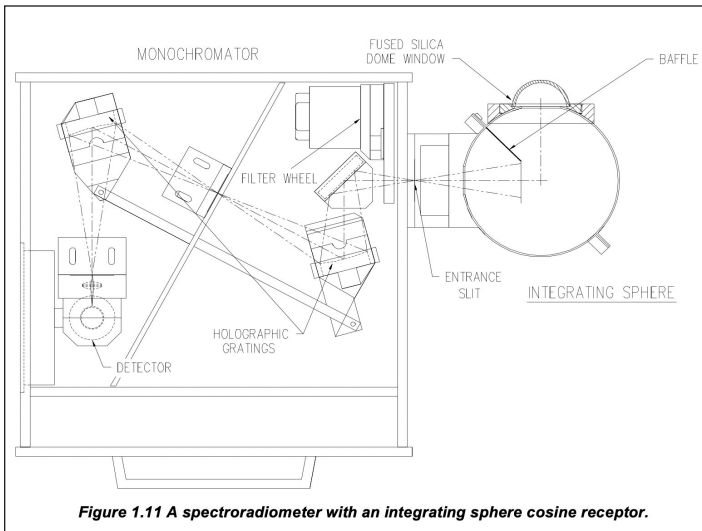

Figure 1.11 A spectroradiometer with an integrating sphere cosine receptor.

Once the spectroradiometer has been calibrated for spectral irradiance response over the wavelength range of interest, it can be used to measure the spectral irradiance of the test source, $E^i(\lambda)$, using the relationship:

$$E^i(\lambda) = \Psi(\lambda) \cdot s^i(\lambda)$$

where, $s^i(\lambda)$ = Photodetector Signal at each Wavelength

The spectral irradiance response calibration factors for the system can be converted to spectral radiant power simply by multiplying the calibration factors by the area of the entrance port of the integrating sphere. Thus, the spectroradiometer can now be used to measure the spectral radiant power of a source provided all of the flux emitted by the source is collected by the integrating sphere.

1.5.1.2. Spectral Irradiance / No Input Optics

Under certain measurement conditions, no special input optics are needed. For example, input optics are not required when measuring the spectral irradiance of point sources or collimated sources if the spectroradiometer responds uniformly over the angular field that the source subtends with the monochromator (or other optical dispersing element). Both the spatial transmission of the monochromator and the uniformity of the photodetector over its sensing area contribute to the spectroradiometer's overall spatial uniformity.

Calibration of a spectroradiometer having no input optics for spectral irradiance response can be accomplished using the 1000 W, 200 W or 45 W lamp standards of spectral irradiance. The "plug-in/pre-aligned" standards are not recommended in this case since the source does not approximate a point source because of the relatively short source-monochromator distance.

1.5.1.3. Spectral Radiance / FOV Baffle Attachment

A field-of-view baffle attachment, as shown in **Figure 1.12**, is a mechanical device that limits the acceptance angle of the detector or monochromator. The FOV baffle attachment must therefore have a larger f-number than the monochromator.

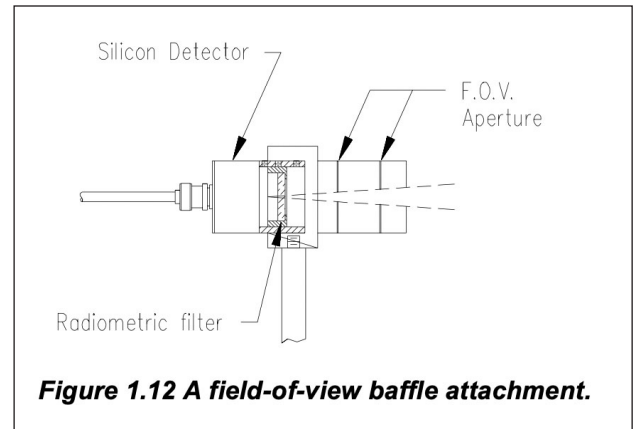

Figure 1.12 A field-of-view baffle attachment.

Such baffles enable the spectroradiometer to measure the spectral radiance of large area, uniformly radiating sources. The source must overfill the FOV of the attachment. The distance from the entrance slit of the monochromator to the source is not critical when making measurements over the visible spectrum as long as the source maintains this overfill condition. An appropriate integrating sphere calibration standard should be used to calibrate the system for spectral radiance response.

1.5.1.4. Spectral Radiance, Radiant Intensity & Irradiance / Telescope

Telescope input optics are used when measuring sources at large distances from the measurement system. In terms of nomenclature, telescope input optics convert the spectroradiometer into a tele-spectroradiometer. A telescope enables the system to measure spectral radiant intensity, spectral radiance, and spectral irradiance.

When measuring spectral radiant intensity or spectral irradiance with a tele-spectroradiometer, the source to be measured should underfill the field of view of the telescope. On the other hand, when measuring spectral radiance, the source should overfill the field of view of the telescope. In general, it is not essential to know the distance from the tele-spectroradiometer to the source when making spectral radiance measurements. However, the distance from the calibration source to the tele-spectroradiometer must be accurately known when calibrating the system for spectral irradiance or radiant intensity response.

Calibration of a tele-spectroradiometer for spectral irradiance response can be accomplished by positioning a 1000 W, 200 W, or 45 W lamp standard at a specified distance from the measurement system. The distance is dependent on the optical characteristics of the telescope. The spectral irradiance standards can also be used to calibrate the tele-spectroradiometer for spectral radiant intensity response as the spectral irradiance of the standards can be converted to spectral radiant intensity simply by multiplying the irradiance by the distance squared.

Calibration of a tele-spectroradiometer for spectral radiance response can be accomplished using an integrating sphere calibration standard. However, as stated above, the radiating area of the calibration standard must overfill the field of view of the telescope.

1.5.1.5. Spectral Radiance / Microscope

Mounting a microscope to the entrance port of the monochromator converts the system into a micro-spectroradiometer. The system can then measure the spectral radiance of small radiating sources. It is essential that the microscope have an accurate viewing system in order to properly image the source on the entrance aperture of the monochromator. In general, when using microscope input optic, the entrance slit of the monochromator is replaced with a small, circular, entrance aperture.

Input microscopes can be obtained with various optics and objective lenses. Calibration of a micro-spectroradiometer for spectral radiance response is easily accomplished using an integrating sphere calibration standard but may be difficult with other sources due to uniformity and working distance considerations.

1.5.1.6. Spectral Irradiance & Radiance / Fiberoptic Probes

Fiberoptic probes can also be coupled directly to the monochromator. They are particularly useful when positioning or alignment of the measuring device with respect to the source is difficult. A probe can be used without additional input optics, or in combination with input optics such as an integrating sphere (for spectral irradiance or spectral radiant flux measurements) a telescope (for spectral radiance, spectral irradiance, or spectral radiant intensity measurements) or with a microscope (for spectral radiance measurements). For most applications involving a microscope, it is generally more convenient to couple the microscope to the monochromator using a fiberoptic probe as shown in **Figure 1.13**.

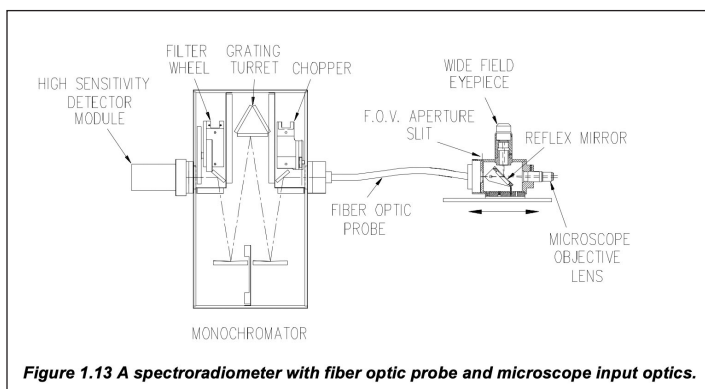

In all cases where the input optics is coupled to the monochromator via a fiber, the appropriate calibration source is the same as that recommended above for the various input optic modules.

1.5.1.7. Spectral Radiance / Imaging Optics

Relatively simple imaging optics consisting of lenses or mirrors

can be used for forming an image of the source on the entrance port of the monochromator. If the imaging optics does not have a viewing system, either the position of the source or the measuring device should be adjusted until a sharp image is visually observed at the entrance port of the monochromator. Imaging optics are used when measuring spectral radiance. Either the tungsten ribbon filament lamp standards of spectral radiance (described in Section 3.3) or the integrating sphere calibration standards can be used to calibrate the measurement system for spectral radiance response.

1.5.2. Spectral Transmittance

Regular spectral transmittance measurements are relatively straightforward. The simplest setup for measuring regular spectral transmittance involves positioning a light source normal to the entrance slit of the monochromator and recording the detector signal with and without the object to be measured in the optical path. The ratio of the signals is the regular transmittance of the object at the wavelength setting of the monochromator.

An instrument dedicated primarily for spectral transmittance measurements is called a spectrophotometer. Spectrophotometers generally have all essential components contained in a single enclosure and quite frequently use a "double beam" optical design. In a double beam spectrophotometer, the light source is split into two fairly equal light paths and recombines at the photodetector. The sample to be measured is inserted in one path and the signal detection system measures the ratio of the "test" signal to the "100%" signal. Although spectrophotometers capable of measuring spectral transmittances as low as 0.01% are readily available, the versatility of spectrophotometers is somewhat limited. Whereas most spectrophotometers are limited to measurements of transmittance and reflectance, a well designed spectroradiometer can be configured to measure spectral output of light sources and spectral response of photodetectors as well as spectral transmittance (both regular and diffuse) and spectral reflectance (both specular and diffuse).

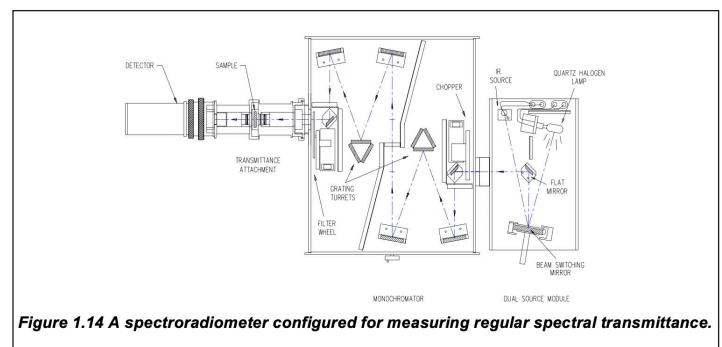

The spectral transmittance of an object is dependent on the nature of the radiating flux, i.e. the transmittance is affected by incident angle, polarization, temperature, etc. Also, the effect of fluorescence must be considered when measuring transmittance. For highest accuracy, it is desirable to measure the transmittance of an object in exactly the same manner in which it will be used. This can be more nearly achieved using a more flexible spectroradiometer. Using a spectroradiometer for transmittance measurements requires a light source module and a transmittance attachment. The versatility of a spectroradiometer enables configuration of the system for broadband (“white light”) illumination of the sample or for monochromatic illumination.

Figure 1.14 shows a spectroradiometer configured for measuring regular spectral transmittance with monochromatic flux incident on the sample.

Diffuse transmittance requires an integrating sphere attachment similar to that shown in **Figure 1.15** for collecting all of the transmitted radiant flux. This design works well with double beam spectrophotometers. A modified version of this attachment can be used either at the input or output of a spectroradiometer. The transmittance measurements made with this attachment measures the total spectral transmittance (sum of regular and diffuse).

1.5.3. Spectral Reflectance

The spectral reflectance of an object is also dependent on the nature of the radiating flux, and whether or not the incident flux is broadband or monochromatic is of particular importance. Fluorescence is quite common when an object is irradiated with broadband flux. The effect of fluorescence is eliminated when the incident flux is monochromatic. In many cases, the reflectance of an object when irradiated by a particular light source is required. As with spectral transmittance measurements, spectroradiometers can be configured with source modules and reflectance attachments to suit the measurement requirement.

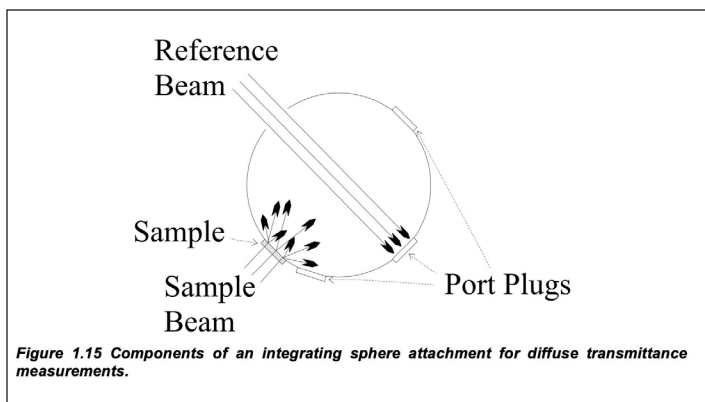

Figure 1.15 Components of an integrating sphere attachment for diffuse transmittance measurements.

1.5.3.1. Spectral Reflectance with Monochromatic Incident Flux.

Figure 1.16 shows the optical layout of a spectroradiometric system configured to measure spectral specular reflectance as a function of the incident angle with monochromatic flux incident on the sample. In this case, a dual source module is mounted at the input to a double grating monochromator. A variable angle, all mirror, specular reflectance attachment is mounted at the exit port

of the monochromator. An important feature of this design is the “self-calibration” capability. Accurate measurements can be made without the use of an auxiliary standard (*calibrated mirror*). The flexible receiver design enables the detector to be positioned at the 0 incident angle position for a 100% reading. Specular reflectance measurements can then be made for various angles of incidence.

1.5.3.2. Spectral Reflectance with Broadband Incident Flux.

Measurements of spectral specular reflectance with broadband flux incident on the sample can be made simply by mounting the reflectance attachment between the source module and the monochromator. For these measurements, the detector is now mounted at the exit port of the monochromator and a fiber optic probe couples the reflectance attachment to the entrance port of the monochromator.

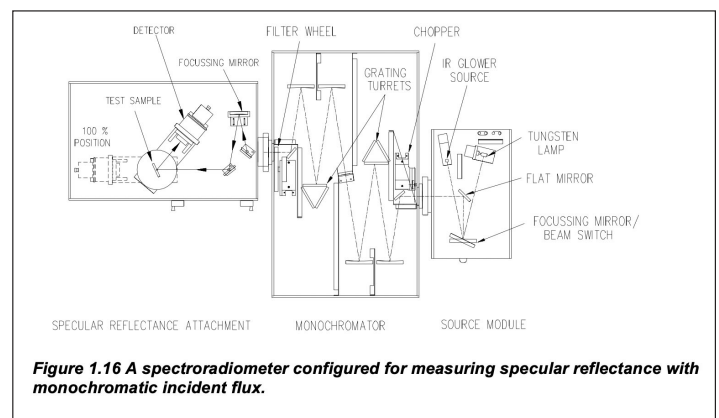

Figure 1.16 A spectroradiometer configured for measuring specular reflectance with monochromatic incident flux.

1.5.3.3. Diffuse Reflectance with Monochromatic Incident Flux

Figure 1.17 shows the optical layout of a spectroradiometric measurement system configured for measuring diffuse reflectance with monochromatic incident flux. The integrating sphere reflectance attachment uses an accurate, double-beam design with an automatic or manually controlled optical beam switching mirror. The double beam design enables the user to use the significantly more accurate “Comparison Method” of measuring diffuse reflectance. This particular version incorporates a sample compartment directly in front of the entrance port of the integrating sphere that enables the user to measure the transmittance or regular or diffusely transmitting samples. A removable specular light trap enables the user to make diffuse reflectance measurements with or without the specular component included. The optical design also enables the user to measure specular reflectance at a fixed angle of incidence.

For highest accuracy, a calibrated, diffuse reflectance plaque should be used as the reference standard when making diffuse

reflectance measurements over the visible spectrum. A plaque coated with PTFE is generally considered superior to other coatings. PTFE has a diffusely reflecting surface with a reflectance above 99% over the visible spectrum.

1.5.3.4. Diffuse Reflectance with Broadband Incident Flux.

Measurements of spectral diffuse reflectance with broadband flux incident on the sample can be made simply by mounting the integrating sphere reflectance attachment between the source module and the monochromator. For these measurements, the detector is now mounted at the exit port of the monochromator and a fiber optic probe couples the reflectance attachment to the entrance port of the monochromator.

1.5.4. Spectral Responsivity.

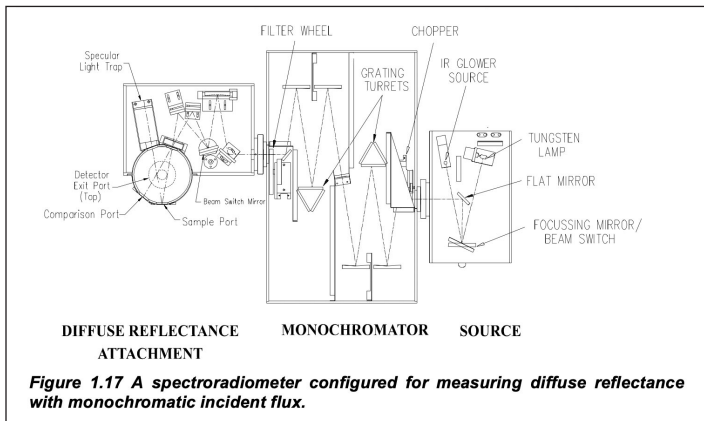

Figure 1.17 A spectroradiometer configured for measuring diffuse reflectance with monochromatic incident flux.

Figure 1.18 shows the optical layout of a spectroradiometric system configured to measure the spectral response of photodetectors. In this case, the input optics consists of source module mounted at the entrance port of a double grating monochromator and a reflective collimating exit optics module mounted at the exit port of the monochromator. The detector, either standard or test, is mounted to the exit optics module.

Measuring power or irradiance response of a photodetector is a two step procedure. The first step involves positioning the standard detector in the collimated beam and measuring the monochromatic flux or irradiance. Monochromatic flux can be determined from:

$$\Phi(\lambda) = \frac{S^s(\lambda)}{R^s(\lambda)}$$

where, $R^s(\lambda)$ = spectral power response of standard detector,

$S^s(\lambda)$ = standard detector signal at each wavelength.

The standard detector is replaced by the test detector and the spectral power response of the test detector, $R^t(\lambda)$, is determined from:

$$R^t = \Phi(\lambda) \cdot S^t(\lambda)$$

where, $S^t(\lambda)$ = test detector signal at specified wavelength.

The irradiance response is measured in the same manner as the power response except that the entire detector (both standard and test) is uniformly irradiated and the irradiance response of the

standard detector is used in the computation as opposed to the power response.

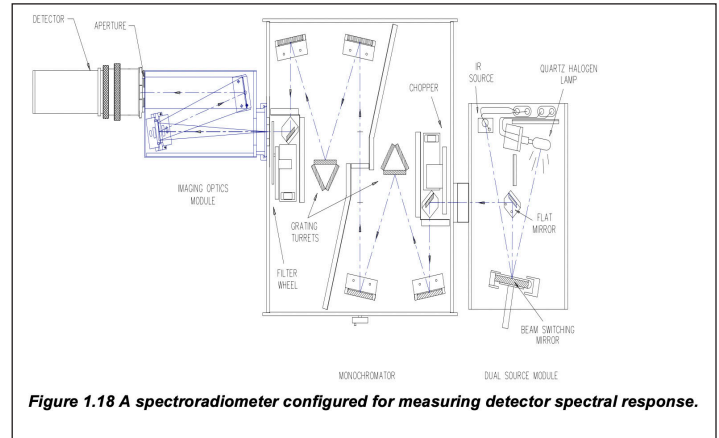

Figure 1.18 A spectroradiometer configured for measuring detector spectral response.

Measurements over the visible spectrum generally employ a NIST traceable standard silicon detector. Since most silicon detectors are quite uniform in sensitivity over the visible spectrum, and in many instances the area of the standard detector is exactly 1 cm², the power response (in A W⁻¹) and irradiance response (in A W⁻¹ cm²) are identical. Typical uncertainties in measuring the monochromatic flux or irradiance over the visible spectrum are on the order of 1%.

1.6. CALCULATING PHOTOMETRIC AND COLORMETRIC PARAMETERS

1.6.1. Tristimulus Values

Chromaticity values may be calculated for sources (datafile in radiometric units) or objects (datafile in fractional transmittance or reflectance). For objects, values represent the color as seen under a standard illuminant (A, B, C or D65).

1.6.1.1. Sources

The X, Y and Z tristimulus values for sources are calculated using the CIE 1931 spectral tristimulus values, $x(\lambda)$, $y(\lambda)$, $z(\lambda)$ as follows:

$$X = \sum_{\lambda=380}^{780} E(\lambda) \bar{x}(\lambda) \Delta\lambda$$

$$Y = \sum_{\lambda=380}^{780} E(\lambda) \bar{y}(\lambda) \Delta\lambda$$

$$Z = \sum_{\lambda=380}^{780} E(\lambda) \bar{z}(\lambda) \Delta\lambda$$

where: $E(\lambda)$ = Spectral Values of the Datafile

$\bar{x}(\lambda)$, $\bar{y}(\lambda)$, $\bar{z}(\lambda)$ = CIE 1931 Spectral Tristimulus Values

λ = Wavelength Interval of the Datafile [nm]



Application Note: A14 Jan 2019

As part of our policy of continuous product improvement, we reserve the right to change specifications at any time.

1.6.1.2. Objects

The X, Y and Z tristimulus values for objects are calculated using the CIE 1931 spectral tristimulus values, $\bar{x}(\lambda)$, $\bar{y}(\lambda)$, $\bar{z}(\lambda)$ as follows:

$$X = k \sum_{\lambda=380}^{780} \bar{E}(\lambda) \Gamma(\lambda) \bar{x}(\lambda) \Delta\lambda$$

$$Y = k \sum_{\lambda=380}^{780} \bar{E}(\lambda) \Gamma(\lambda) \bar{y}(\lambda) \Delta\lambda$$

$$Z = k \sum_{\lambda=380}^{780} \bar{E}(\lambda) \Gamma(\lambda) \bar{z}(\lambda) \Delta\lambda$$

$$k = \frac{100}{\sum \bar{E}(\lambda) \bar{y}(\lambda) \Delta\lambda}$$

where: \bar{E} = Relative Spectral Power of an Illuminant

$\Gamma(\lambda)$ = Spectral Reflectance or Transmittance Data

$\bar{x}(\lambda)$, $\bar{y}(\lambda)$, $\bar{z}(\lambda)$ = CIE 1931 Spectral Tristimulus Values

$\Delta\lambda$ = wavelength interval of the datafile [nm]

The $\bar{x}(\lambda)$, $\bar{y}(\lambda)$, $\bar{z}(\lambda)$ values that are used in the above equations refer to a 2° field-of-view observer. Equivalent X_{10} , Y_{10} & Z_{10} values for a 10° field-of-view can be similarly calculated using the CIE 1964 supplementary spectral tristimulus values.

1.6.2. Photometric Output Calculations

For sources, the photometric output (in this case illuminance, E_v) is calculated by:

$$E_v [\text{lm cm}^{-2}] = Y [\text{W cm}^{-2}] \cdot 683 [\text{lm W}^{-1}]$$

For objects, the value of Y is expressed in percent and is the photometric transmittance or reflectance.

1.6.3. CIE 1931 Chromaticity Calculations

The x, y and z chromaticity coordinates of the datafile are calculated from the tristimulus values X, Y, Z as follows:

$$x = \frac{X}{X + Y + Z}$$

$$y = \frac{Y}{X + Y + Z}$$

$$z = \frac{Z}{X + Y + Z}$$

1.6.4. UCS 1976 u, v, u', and v' Coordinates Calculations

The UCS 1960 u, v coordinates are calculated:

$$v = \frac{6y}{12y - 2x + 3} = \frac{2}{3} v'$$

$$u = \frac{4x}{12y - 2x + 3} = u'$$

The UCS 1976 u' and v' coordinates are calculated:

$$u' = \frac{4x}{12y - 2x + 3} = u$$

$$v' = \frac{9y}{12y - 2x + 3} = \frac{3}{2} v$$

1.6.5. Correlated Color Temperature Calculations

Correlated color temperature calculations are based on Robertson's method (29) using a table of 30 isothermperature lines. Robertson's successive approximation method should be accurate to calculate correlated color temperatures to within 0.1 μrd (the micro reciprocal degree, $\mu\text{rd} = 10^6/T$ where T is the temperature in Kelvin). The maximum error from 1600 to 3000 K should be less than 0.2 K plus the measurement uncertainty. Robertson states that the errors may be larger for sources with chromaticities farther than 0.01 from the Planckian locus. However, the concept of correlated color temperature has little meaning outside the immediate vicinity of the Planckian locus.

1.6.6. CIE LAB / LUV Color Space Calculations

CIE LAB Color Space Calculations are performed as per the recommended 1976 CIE formulas. For Source computations, X, Y and Z are normalized equally such that Y = 100. The equations are as follows:

$$L^* = 116 \left(\frac{Y}{Y_n} \right)^{1/3} - 16$$

$$a^* = 500 \left[\left(\frac{X}{X_n} \right)^{1/3} - \left(\frac{Y}{Y_n} \right)^{1/3} \right]$$

$$b^* = 200 \left[\left(\frac{Y}{Y_n} \right)^{1/3} - \left(\frac{Z}{Z_n} \right)^{1/3} \right]$$

Here X_n , Y_n and Z_n are tristimulus values of the reference white. The equations above are modified slightly when X/X_n , Y/Y_n or Z/Z_n is less than .01. The modified equations are shown below:

$$L^* = 116 \left[f \left(\frac{Y}{Y_n} \right) - \left(\frac{16}{116} \right) \right]$$

$$a^* = 500 \left[f \left(\frac{X}{X_n} \right)^{1/3} - f \left(\frac{Y}{Y_n} \right)^{1/3} \right]$$

$$b^* = 200 \left[f \left(\frac{Y}{Y_n} \right)^{1/3} - f \left(\frac{Z}{Z_n} \right)^{1/3} \right]$$

where $f(Y/Y_n) = (Y/Y_n)^{1/3}$ for Y/Y_n greater than 0.008856 and $f(Y/Y_n) = 7.787(Y/Y_n) + 16/116$ for Y/Y_n less than or equal to 0.008856; $f(X/X_n)$ and $f(Z/Z_n)$ are similarly defined.

$$u^* = 13L^*(u' - u_n')$$

$$v^* = 13L^*(v' - v_n')$$

OPTRONIC™
LABORATORIES

Application Note: A14 Jan 2019

As part of our policy of continuous product improvement, we reserve the right to change specifications at any time.

For sources, values represent a comparison to a standard illuminant for an ideal white object. For objects, values represent a comparison to an ideal white object under a given standard illuminant.

1.6.7. Color Difference and Color Rendering Calculations

Detailed calculations of color differences and color rendering indices are beyond the scope of this section, but are reviewed elsewhere (30). However, these are routinely used commercially as indicators of lamp performance and a brief discussion of their significance is in order.

Two sources may have the same chromaticities or correlated color temperature and yet be spectrally different. When a transmitting or reflecting sample is viewed under these sources, it is therefore possible that different chromaticities result for each source. Differences in chromaticities are normally calculated in some uniform color space (e.g. Lab, Luv or CIE 1964 WUV). The agreement (expressed in percent) between any source and a reference illuminant is termed color rendering.

The CIE has specified the standard method for assessing the color rendering properties of sources (31-33). The method consists of a series of "special color-rendering indices" and an average "general color-rendering index." Each of the special color-rendering indices represents CIE 1964 color differences between the chromaticities for 14 specified samples under the test source and a specified reference illuminant. The first eight of these specific color-rendering indices are averaged to give the general color-rendering index. The closer the general color rendering index is to 100%, the more the test source is thought to resemble the reference illuminant.

1.6.8. Detector Photometric Parameters

Several photometric parameters, specified by CIE, may be used to reflect the performance of a photopic detector. Essentially these values represent to agreement between the response of a detector and the CIE standard observer. By far the most frequently quoted, and hence measured, of these parameters is the f_1' value. This parameter represents an overall "goodness of fit" rather than an accuracy at a specific wavelength, and is given by:

$$f_1' = \frac{\int |\bar{R}(\lambda) - V(\lambda)|}{\int V(\lambda)} \cdot 100 \quad [\%]$$

where: $\bar{R}(\lambda)$ is the detector response and $V(\lambda)$ is the CIE standard observer response.

The parameter is expressed in percent, with lower values indicating a better fit to the standard observer. As this value approaches zero, the errors introduced by calibrating with a lamp of one spectral distribution and measuring a lamp of another spectral distribution rapidly diminish. Opinions differ on the range of values that are acceptable for photopic measurements, largely because it depends so much on the source, but most experienced users agree that if the calibration and test source differ considerably then a fit to within 2% is required. This is generally only achievable by measuring the unfiltered detector response and "tailoring" the filter to match. For less demanding applications,

values of less than 5% are generally acceptable.

1.6.9. Limits in Using Photometric and Colorimetric Calculations

When calculating correlated color temperature or dependent parameters such as color rendering index, it should be borne in mind that these assume a blackbody or similar spectral distribution. Many sources in common use, e.g. fluorescent lamps or LEDs, have spectral distributions very different from that of a blackbody. Although results may be obtained, and indeed the lighting industry often uses these parameters to characterize their lamps, results should be interpreted with caution.

1.7. ACCURACY AND ERRORS

1.7.1. Random, Systematic and Periodic errors

These three types of error are the fundamental components limiting the accuracy of any measurement. Each is, at least theoretically, distinct and separable but in practical situations a huge amount of work is required to isolate them from each other.

Figure 1.19 illustrates these basic types of error where:

Random errors are variations about the mean that, if sampled sufficiently, would form a gaussian or other similar statistical function. These errors decrease with increased sampling, either by longer integration times or by multiple scans.

Systematic errors are offsets to the "true" value. These are, by definition, constant and do not change by multiple sampling. Often these errors are due to basic assumptions not being realized in practice.

Periodic errors are those that arise from periodic or pseudo-periodic events. Such examples include variations due to air-conditioning changing the local temperature or AC interference from sources or line voltages.

The statistical distributions of these different types of error are given in **Figure 1.20**.

When specifying the accuracies of a measurement, these individual errors must be estimated and combined. Most standards laboratories quote errors to be 2 or 3 standard deviations (approximately 95% or 99% confidence levels respectively), but since only one type of error - random - has any significance expressed in this way, the interpretation of these values may be difficult for the user.

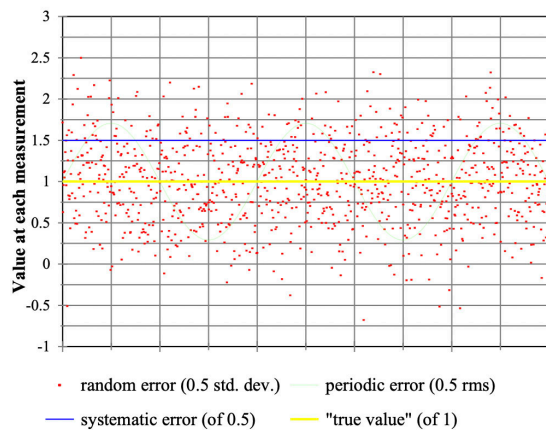

Figure 1.19 Types of error in measurements.

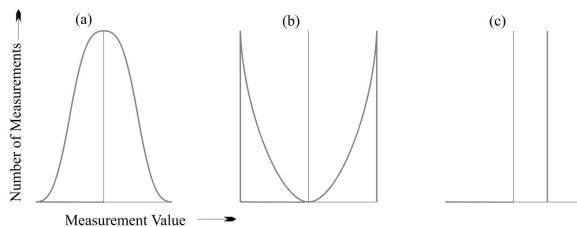

Figure 1.20 Statistical distributions about a central "true" value of (a) random errors, (b) simple periodic errors and (c) systematic errors.

1.7.2. Error Sources Photometry and Spectroradiometry

To illustrate the effects of these errors on an actual measurement, consider the use of a photometer in the determination of the illuminance from a light source at some specific distance. In this measurement we would expect:

Random Noise from:

- The Detector
- Electronics
- Light Source

Systematic Errors from:

- The measurement of the distance
- Any error in the calibration factor of the photometer, including errors associated with the calibration light source
- Non-cosine collection of light
- Differences between the detector relative spectral response and the $V(\lambda)$ function
- Differences between the calibration source spectral distribution and the test source spectral distribution
- Stray light from reflections off walls and objects and emission from other sources, e.g. computer screens, in the laboratory
- Non-linearity of the detector/amplifier combination with intensity
- Errors associated with setting the true dark level of the system (*i.e. the average of the dark noise*).

Periodic Errors from:

- Temperature, humidity and air-movement variations affecting the response and spectral characteristics of the photometer or the intensity of the light source
- Drift of zero levels or gain in the detector/amplifier
- Stray light variations due to movement of objects, personnel, changing computer screen displays and daylight "leaks" into the laboratory
- Sampling errors and "beating" when measuring AC sources or if AC "pickup" is significant.

From the above list, it should be apparent that just because close agreement of results is obtained between several measurements, this does not imply that they are accurate. Confidence in the accuracy of results is only achieved when all sources of error have been quantified, minimized and where possible eliminated.

Spectroradiometric measurements exhibit many of the above sources of error to some extent. However, the accuracy of spectroradiometric results is generally much better since:

- Spectra contain many data points. The calculation of the integrals as described in section 1.6 effectively reduces the contribution of errors associated with each data point in proportion to the $V(\lambda)$ function and integrates noise in much the same way as multiple sampling does.
- The systematic error of matching the photometer response to the $V(\lambda)$ function can often represent the greatest limit on the accuracy of broadband measurements. For spectroradiometric systems, the actual $V(\lambda)$ function is used in calculations, so it may be considered to represent an "ideal" photometer.
- Differences between the spectral distributions of the calibration and test source are not relevant since these are determined.
- Autoranging can occur at each wavelength of measurement, rather than for the entire measurement as a whole, giving a better representation of the source, minimizing errors and extending the dynamic range.

LIST OF REFERENCES

- 1 Boyd, R.W., Radiometry and the Detection of Optical Radiation, New York, John Wiley & Sons, 1983, ch. 6, pp. 95-97.
- 2 Cromer, C.L., "A New Spectral Response Calibration Method using a Silicon Photodiode Trap Detector," to be published in the Journal of Research of the National Institute of Standards and Technology.

OPTRONIC™
LABORATORIES

Application Note: A14 Jan 2019

As part of our policy of continuous product improvement, we reserve the right to change specifications at any time.

- 3 DeVos, J.C., *Physica* 20, pp. 669 (1954).
- 4 Eckerle, K.L., Hsia, J.J., Mielenz, K.D., and Weidner, V.R., *Regular Spectral Transmittance*, NBS Special Publication 250-6, (1987).
- 5 Eppeldauer, G., and Hardis, J.E., *Applied Optics* 30, pp. 3091-3099 (1991)
- 6 Gouffé, A., *Revue d'Optique* 24, pp. 1 (1945)
- 7 Grum, F., and Bartleson, C. J., *Optical Radiation Measurements Volume 2*, New York: Academic Press, 1980, ch. 3, pp. 134-142.
- 8 Grum, F., and Becherer R.J., *Optical Radiation Measurements, Volume 1*, New York: Academic Press, 1979, ch. 2, pp. 12-13.
- 9 Hecht, E., and Zajac, A., *Optics*, Reading, MA: Addison-Wesley Publishing Co., 1974, ch. 4, pp. 62-63.
- 10 Kirchoff, G., *Philosophical Magazine and Journal of Science* 4th Series 20, No. 130, (1860).
- 11 Kostkowski, H.J., Erminy, D.E., Hattenburg, A.T., *Advances in Geophysics* 14, pp. 111-127 (1970).
- 12 "Method of Measuring and Specifying Colour Rendering Properties of Light Sources", CIE publication number 13.3, 1995
- 13 "Method of Measuring and Specifying Colour Rendering of Sources", CIE publication number 13.2, 1974
- 14 "Method of Measuring and Specifying Colour Rendering of Sources, 2nd. Ed. (corrected)", CIE publication number 13.2, 1988
- 15 Mielenz, K.D., Saunders, R.D., Parr, A.C., Hsia, J.J., *J. Res. National Institute of Standards Technology* 95, pp. 621 (1990).
- 16 Robertson, A. R., *J. Opt. Soc. Am.* 58, pp. 1528 (1968)
- 17 Saunders, R.D., and Shumaker, J.B., *The 1973 NBS Scale of Spectral Irradiance*, NBS Technology Note 594-13, (1977)
- 18 Schneider, W.E., *Lasers and Optronics* 12, No. 1, pp. 29 -32 (1993).
- 19 Schneider, W.E., "Spectral Ultraviolet Measurements and Utilization of Standards," Presented at the Critical Issues in Air Ultraviolet Metrology Workshop at NIST, Gaithersburg, MD, May 25-26 (1994).
- 20 Schneider, W.E., *Test and Measurement World* 6, pp. 159-169 (1985).
- 21 Schneider, W.E., and Goebel, D.G., *The International Journal for Optical Engineering Proceedings* 262, pp. 74-83 (1981).
- 22 Schneider, W.E., and Goebel, D.G., *Laser Focus/Electro-Optics* 20, No. 9, pp. 82-96 (1984).
- 23 Schneider, W.E., and Miller, K.A., *The Photonics Design & Application Handbook*, 41st Ed., Pittsfield, MA: Laurin Publishing Co., 1995, pp. 36-44 .
- 24 Stair, R., Johnston, R.G., and Halbach, E.W., *NBS Journal of Res.* 64A, pp. 291-296, (1960).
- 25 Stair, R., Schneider, W.E., and Jackson, J.K., *Application Optics* 2, pp. 1151-1154, (1963).
- 26 Smith, W.J., *Modern Optical Engineering*, 2nd Ed., New York: McGraw-Hill, Inc., 1990, ch. 8, pp. 217
- 27 Walker, J.H., Saunders, R.D., and Hattenburg, A.T., *Spectral Radiance Calibrations*, NBS Special Publication 250-1, (1987)
- 28 Walker, J.H., Saunders, R.D., Jackson, J.K., and McSparren, D. A., *Spectral Irradiance Calibrations*, NBS Special Publication 250-20, (1987).
- 29 Wolfe, W.L., and Zissis, C.J., *The Infrared Handbook*, Revised Ed., Washington D.C.: Office of Naval Research, Dept. Of The Navy, 1989, ch.1, pp. 29.
- 30 Young, R., and Schneider, W.E., *Laser Focus World* 31, No. 5, pp. 215-220 (1995).
- 31 Zalewski, E.F., *The NBS Photodetector Spectral Response Calibrations Transfer Program*, NBS Special Publication 250-17, (1988)
- 32 Zalewski, E.F., and Duda, C.R., *Applied Optics* 22, pp. 2867-2873 (1983).
- 33 Zappa, F., Lacaita, A. L., Cova, S. D., Lovati, P., *Opt. Eng.* 35, No. 4, pp. 938-945 (1996)

OPTRONIC™
LABORATORIES

Application Note: A14 Jan 2019

As part of our policy of continuous product improvement, we reserve the right to change specifications at any time.